

**3 way automatic rotary disc valve**  
**Vanne à ecluse rotative 3 voies automatique**  
**Válvula 3 vías rotativa actuada**  
**Válvula de comporta rotativa de 3**  
**vía automática**  
**Valvola selettiva a 3 vie**  
**automatica**  
**3 Weg Drehklappen**  
**automatische**

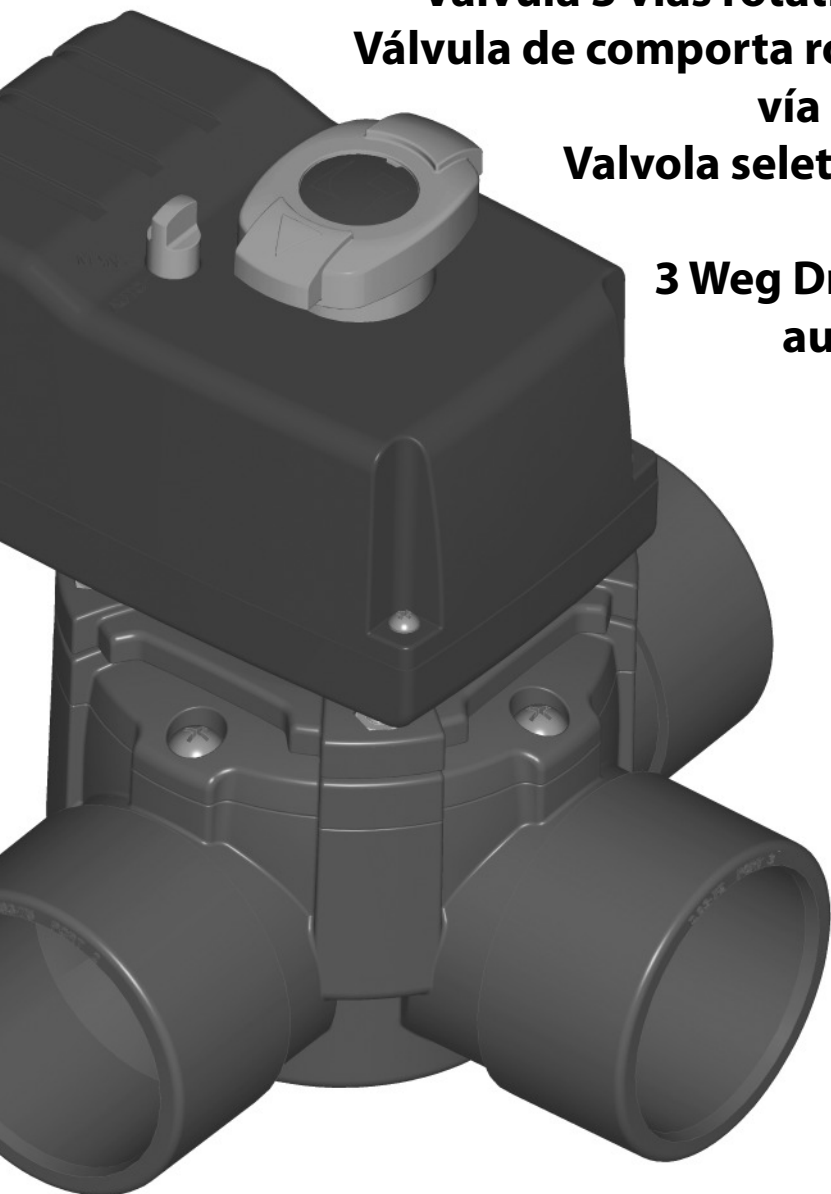

# Declaración de conformidad CE / *EC Declaration of Conformity*

**Motor válvula compuerta rotatoria 230 Vac / *Rotary disc automatic actuator 230 Vac***

**Motor válvula compuerta rotatoria 24 Vac / *Rotary disc automatic actuator 24 Vac***

**El fabricante / *the manufacturer* :** CEPEX,S.A.U.

Avinguda Ramon Ciurens 40 (Parcel·la 6)  
Polígon Industrial Congost  
08530 LA GARRIGA



**Certifica que nuestro / *declara que nuestro / certify that our/ declares that* :**

**Tipo / *type*:**

Motor válvula compuerta rotativa 230 Vac

*Rotary disc automatic actuator 230 Vac*

**Modelo/Model:** 059073030

Motor válvula compuerta rotativa 24 Vac

*Rotary disc automatic actuator 24 Vac*

**Modelo/Model:** 059073030A24

cumple con los requisitos establecidos por la UNIÓN EUROPEA en COMPATIBILIDAD ELECTROMAGNÉTICA de acuerdo a las siguientes normas:

*is according to requirements established by the EUROPEAN UNION in the ELECTRICAL MAGNETIC COMPATIBILITY (EMC) DIRECTIVE 89/336/CE according to following standards:*

## **UNE-EN 61000-6-1**

Compatibilidad Electromagnética (CEM). Parte 6: Normas genéricas. Sección 1: Inmunidad en entornos residenciales, comerciales y de industria ligera.

*Electromagnetic compatibility (EMC). Generic standards. Immunity for residential, commercial and light-industrial environments.*

## **UNE-EN 61000-6-3**

Compatibilidad Electromagnética (CEM). Parte 6: Normas genéricas. Sección 3: Norma de emisión en entornos residenciales, comerciales y de industria ligera.

*Electromagnetic compatibility (EMC). Generic standards. Emission standard for residential, commercial and light-industrial environments.*

## **UNE-EN 60730-2-8**

Dispositivos de control eléctrico automático para uso doméstico y análogo. Parte 2-8: Requisitos particulares para electroválvulas hidráulicas, incluyendo los requisitos mecánicos.

*Specification for automatic electrical controls for household and similar use. Particular requirements. Particular requirements for electrically operated water valves, including mechanical requirements.*

Y Por el cumplimiento de estas directivas , nuestro actuador puede incorporar la marca CE

*By accomplishing these directives , our actuator can incorporate the CE mark.*

Y ser vendidos en la UNIÓN EUROPEA cumpliendo con los requisitos legales.

*And they can be sold throughout EUROPEAN UNION providing all legal requirements.*

Mr. Ramon Salichs, Director / Manager  
La Garriga, Octubre 2009

**INDEX**

0. General advisors ..... 3  
 1. Technical characteristics ..... 3  
 2. Electrical connection ..... 4  
 3. Automatic operation ..... 6  
 4. Manual operation ..... 6  
 5. Spare parts ..... 6  
 6. Actuated 3 way rotary disc valve ..... 7  
 7. Potential problems and solution ..... 7

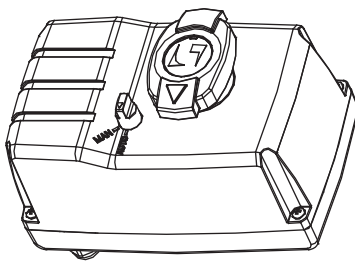

**0. General advisors**

- o Read the instructions before the connection of the actuator and follow the recommendations mentioned here. The guarantee will no cover the damages caused if you don't follow these advisors.
- o The connection and manipulation operations will be done by qualified people.
- o Shut off the power supply before removing the cover.
- o Useful life extension: 5.000 manoeuvres - 180 °.
- o The actuator has to be protected by external fuses or any other circuit breaker.
- o Be careful that there are no objects inside the mechanism that can cause any damage.
- o Pay attention to avoid water inside the cover.
- o This apparatus is not recommended for installation in the open air.
- o Always stop pump before changing the position.

**1. Technical characteristics**

- o Output Nominal Torque = 4,25 N·m
- o Output speed = 0,6 min<sup>-1</sup>
- o Power = 5 W.
- o 90° turning time laps = 26 s (180° - 52 s).
- o Protection degree: IP65
- o Temperature range: 0 – 45 °C.
- o Weight: 1,2 kg
- o Connection ISO 5211 ø50 F05.

Two possible electrical configurations:

- 230 Vac / 50 -60 Hz.
- 24 Vac / 50 - 60 Hz.

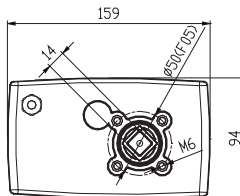
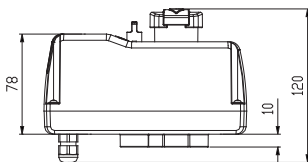

**2. Electrical connection**

The valve is supplied with a 4 wire x 1 mm<sup>2</sup> cable. You must connect it following the drawing printed in the actuator cover. The drawing indicates the external connection: an external relay must change the turning sense when it changes the signal from black cable to brown cable. For changing the electrical connection of the valve, it is necessary to remove handle and cover of the actuator to access to the connection terminal. Then, pass a 4-wire cable (through the bottom gland until the terminals shown in the drawing).

**External connection**

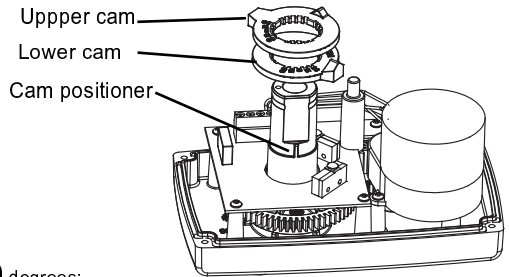
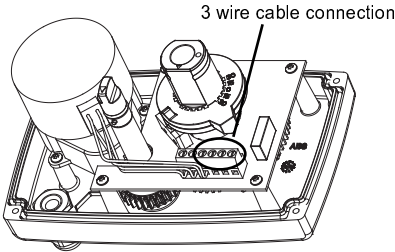
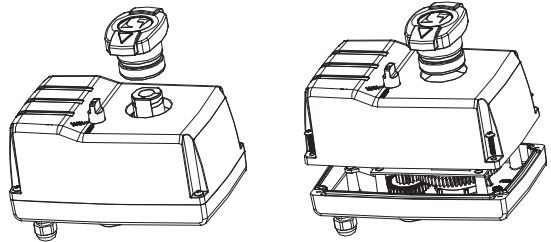
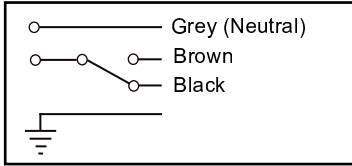

Cams configuration for 3-way rotary disc valve turning **180** degrees:

**Resting position - Right Exit**

**180° position - Left Exit**

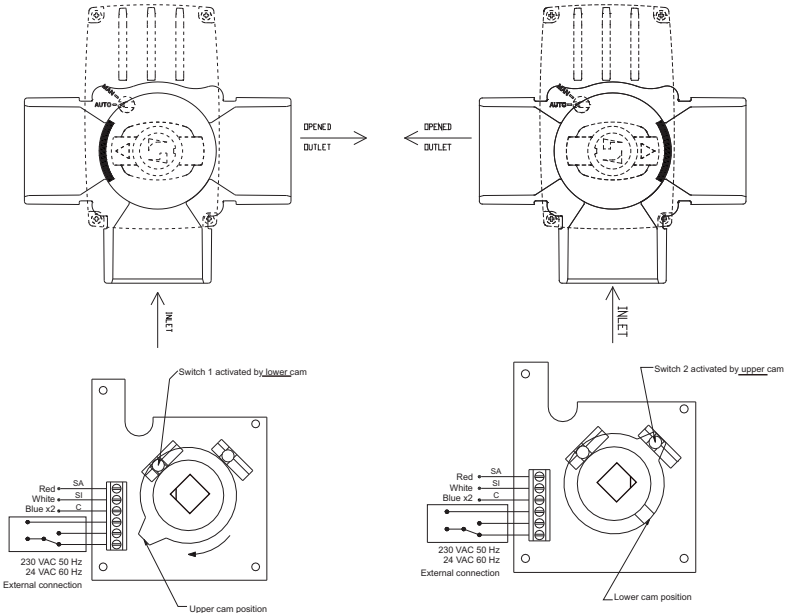

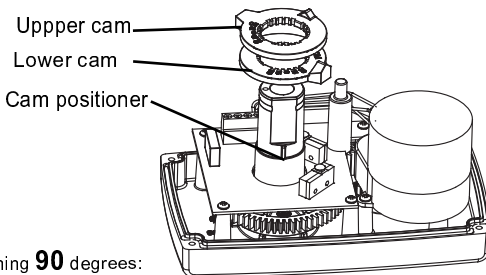
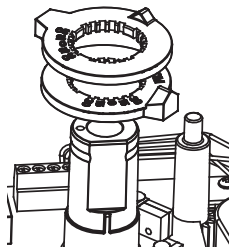

Cams configuration for 3-way rotary disc valve turning **90** degrees:

Resting position - Central Exit

90° position - Right Exit

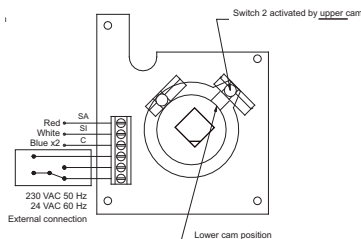
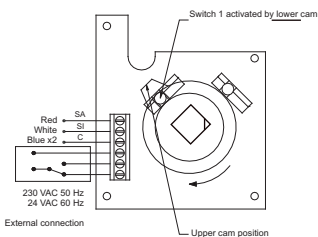
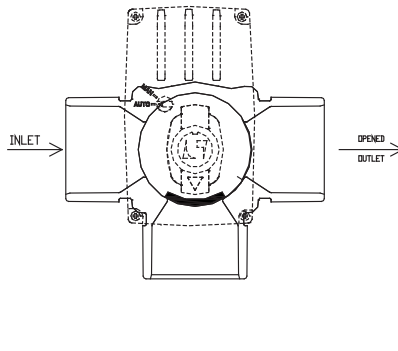
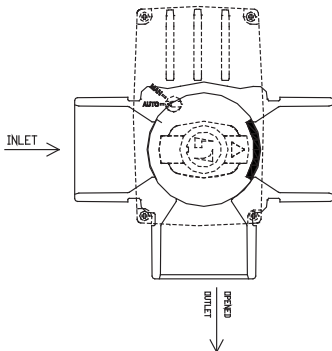

In order to change the turning direction, ask to the manufacturer.

### 3. Automatic operation

The actuator causes the automatic turn of 90 or 180 degrees of the output axis, depending on the position of the two internal cams. In addition, it is possible to place the cams so that the stop position is 15 or 30 degrees before or after the position of closed or opened valve. In order to change the position of the cams, disassemble handle and cover to accede to the cams and then rise and place them in the new position, matching the grooves of the cams with the positioner of the main axis. It is recommended that the configuration is to be done by the manufacturer.

**4. Emergency manual override facility**

Use only when the automatic operation fails.

In order to operate the actuator manually, press the MAN / AUTO selector and turn it to the manual position. Then, the manual operation of the main handle will steer the actuator to the desired position.

It is imperative to stop the engine before pressing the manual / auto selector in order to prevent damage to the gears.

It is advisable to hold pressed the manual/auto selector while the handle is turned manually to prevent contact between the gears.

To return to automatic, turn the manual / auto selector to auto position; make small turns to the main handle to ensure that the manual / auto is back to its initial position (raised) because of the internal spring.

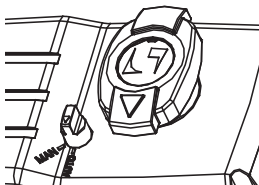

**5. Spare parts**

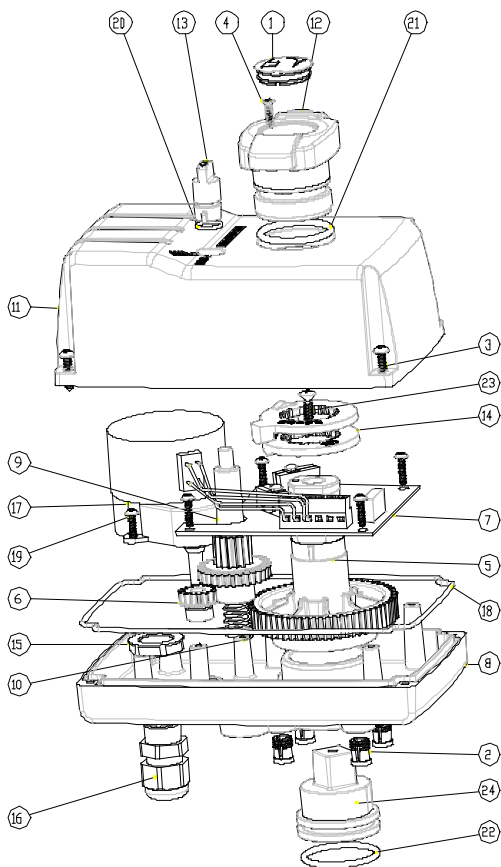

N	CODE	DESCRIPTION	MATERIAL	Q
1	058107506	Cap	PP	1
2	607305016	Insert	Brass	4
3	711435016	Screw	Stainless st	4
4	711429013	Screw	Stainless st	1
5	05907303001	Geared wheel	POM	1
6	05907303002	Motor sprocket	POM	1
7	05907303003	PCB	-	1
8	05907303004	Base	ASA	1
9	05907303005	Double sprocket	POM	1
10	05907303006	Resort	Stainless st	1
11	05907303007	Cover	-	1
12	05907303008	Main handle	PP	1
13	05907303009	Manual selector	PP	1
14	05907303010	Cam	POM	2
15	05907303011	Gland nut	PA	1
16	05907303012	Gland	PA	1
17	05907303013	Geared motor	-	1
18	05907303015	Cover joint	Rubber	1
19	711529013	Screw	Stainless st	6
20	8070091016	O-ring seal	EPDM	1
21	8070280030	O-ring seal	EPDM	1
22	8070298026	O-ring seal	EPDM	1
23	711539019	Screw	Stainless st	1
24	05907303021	Coupling	POM	1

6. Actuated 3 way rotary disc valve

D63

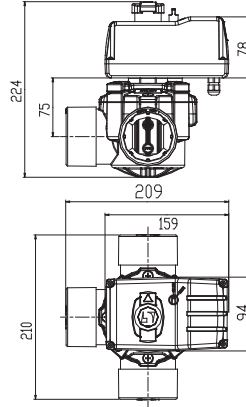
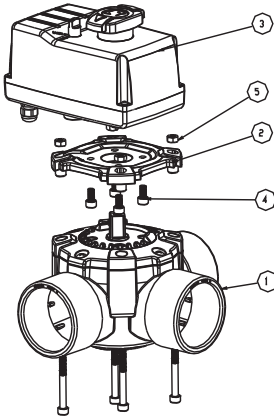

N	CODE	DESCRIPTION	MATERIAL	Q
1	0590740X	3 way rotary disc valve without handle	-	1
2	059074020	Actuator bracket	PVC-U	1
3	059073030 05907303A24	Electric actuator	-	1
4	710706012	Screw	Stainless st	4
5	71206000	Nut	Stainless st	4
6	710706055	Screw	Stainless st	4

D50

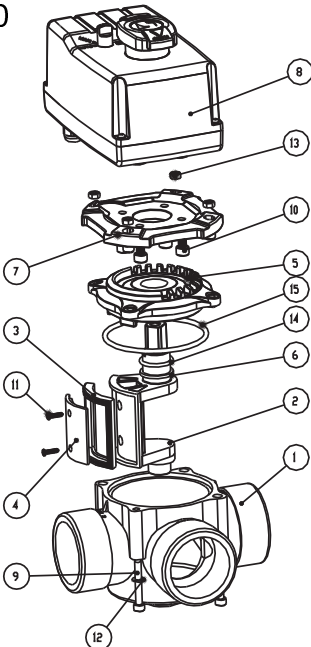

N	CODE	DENOMINACIÓN	MATERIAL	Q
1	059073000	Body	PVC-U	1
2	059073011	Rotary disc	PPO	1
3	059072035	Disc seal	Silicone	1
4	059072002	Disc seal retainer	PPO	1
5	059073013	Cover	PPO	1
6	059072015	Flat gasket	PTFE	
7	059073020	Actuator bracket	PVC-U	1
8	059073030 05907303A24	Electric Actuator	-	1
9	710705060	Screw	Stainless st	4
10	710706012	Screw	Stainless st	4
11	711429013	Screw	Stainless st	2
12	711905000	Washer	Stainless st	4
13	712105000	Nut	Stainless st	4
14	8070219026	O-ring	EPDM	1
15	8070758035	O-ring	EPDM	1

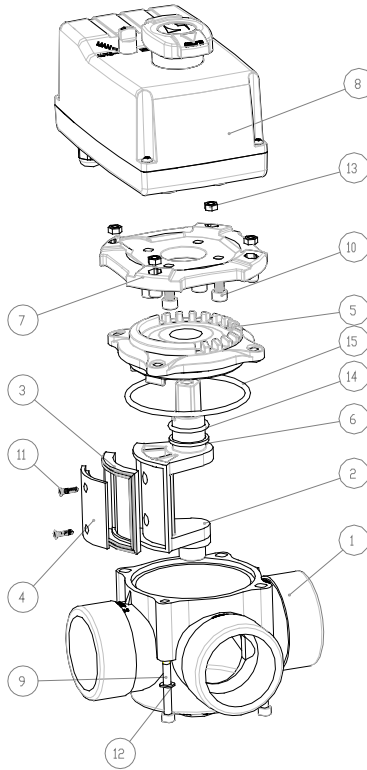

**7. Potential problems and solutions**

<b>PROBLEM</b>	<b>CAUSE</b>	<b>SOLUTION</b>
The valve doesn't turn in the correct sense	Incorrect electrical connection	Change motor white and red cables between them and the same with the relay
The valve turns in the correct sense but the final stop is not in the desired position	The position of the cams is not correct	Remove handle and cover and change the position of the cams according to the manual
	Relay connection is inverted	Reverse the cables of the relay that change the sense of turn (Brown-Black)
	Some of the limit switches doesn't work correctly	The PCB needs to be changed. Contact the wholesaler
The manual turn of the valve is not possible to do	The intermediate sprocket has not to be released from the motor	The manual / auto selector has to be sunken and turned to the manual position
After changing the valve from manual to auto, the automatic device doesn't work	The manual / auto selector doesn't go up after changing the position	In order to be sure that the manual / auto selector returns to the upper position move lightly the main handle to put into gear



## TABLE DES MATIÈRES

0.	Avertissements .....	8
1.	Caractéristiques techniques .....	8
2.	Branchement électrique .....	9
3.	Fonctionnement .....	11
4.	Actionnement manuel .....	11
5.	Composants .....	11
6.	Vanne d'arrêt rotative 3 voies motorisée .....	12
7.	Solution aux problèmes éventuels .....	12

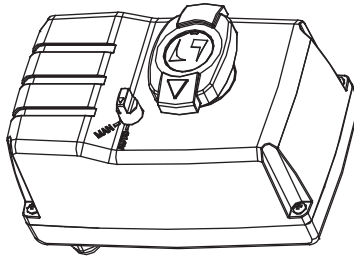

### 0. Avertissements

- o Lire ces instructions avant de raccorder l'actionneur et suivre les recommandations mentionnées ici. Si ces instructions ne sont pas suivies, les dommages ne seront pas couverts par la garantie.
- o Les opérations de raccordement et de manipulation devront être effectuées par du personnel qualifié.
- o Couper l'alimentation avant d'ouvrir le couvercle.
- o Vie utile maximale : 5.000 manœuvres - 180 °.
- o Il est conseillé de protéger l'appareil avec des fusibles indépendants ou avec des protections électriques appropriées.
- o Ne pas laisser à l'intérieur des objets qui peuvent endommager le mécanisme.
- o Il faut veiller particulièrement à ce qu'il n'y ait pas d'eau qui entre à l'intérieur du boîtier.
- o Leur installation est déconseillée en cas d'exposition au mauvais temps.
- o Avant de changer la position de la vanne, arrêtez toujours la pompe.

### 1. Caractéristiques techniques

- o Couple nominal de sortie = 4,25 N•m
- o Vitesse de rotation de sortie = 0,6 min-1
- o Puissance = 5 W.
- o Temps de rotation de 90° = 26 s (180° - 52 s).
- o Degré de protection : IP65
- o Plage de température : 0 – 45 °C.
- o Poids : 1,2 kg
- o Fixation selon ISO 5211 ø50 F05

Deux configurations électriques possibles :

- 230 Vac / 50-60 Hz.
- 24 Vac / 50-60 Hz.

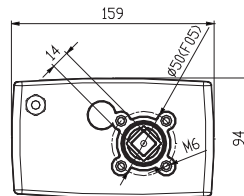
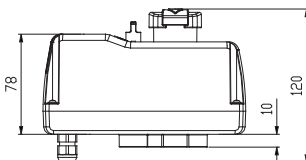

## 2. Branchement électrique

La vanne est livrée avec un câble à 4 fils x 1 mm<sup>2</sup>. Brancher suivant le schéma qui figure sur le couvercle de l'actionneur. Le schéma indique le branchement externe: un relais extérieur doit effectuer le changement de sens de virement, le signal du câble noir au câble marron.

Pour changer le branchement électrique de la vanne, il faut extraire la manette indicatrice et démonter le couvercle de l'actionnement afin d'accéder à la réglette de branchement. Passer un câble à 4 fils par le passe-câble du bas jusqu'à la réglette montrée sur le dessin.

### Branchement externe

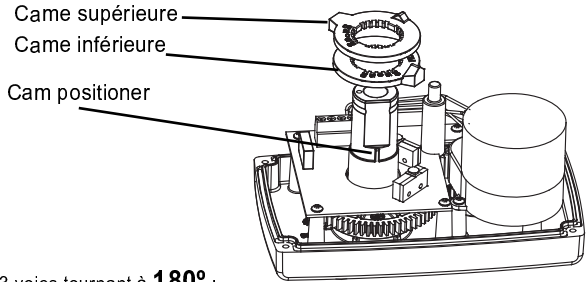
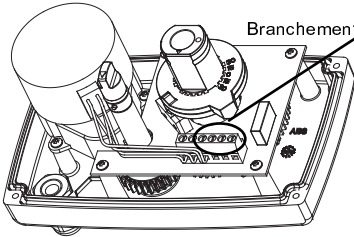
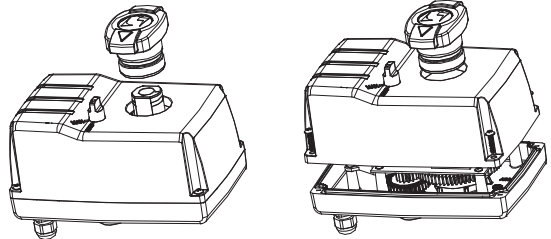
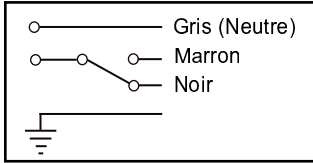

Configuration de cames pour la vanne d'arrêt rotative à 3 voies tournant à **180°** :

Position de repos-Sortie droite

Position 180°-Sortie gauche

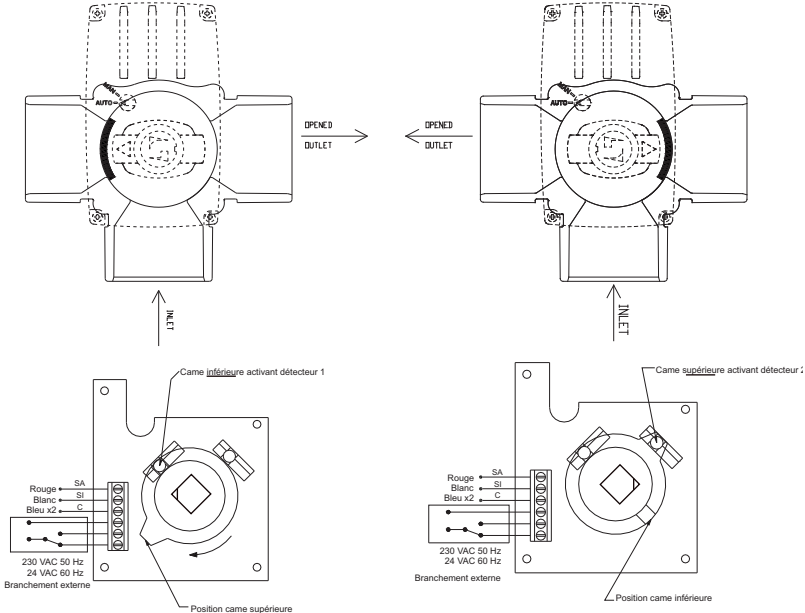

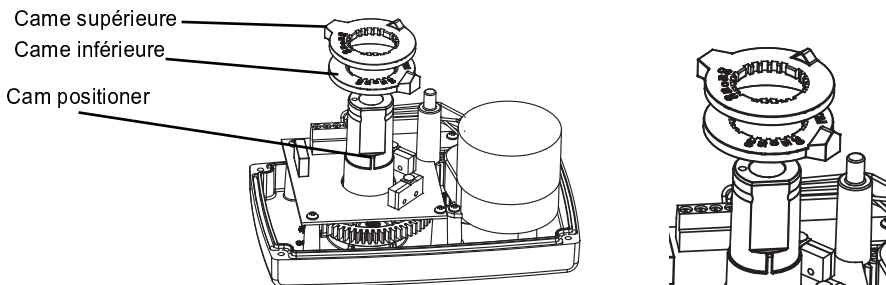

Configuration de cames pour la vanne d'arrêt rotative à 3 voies tournant à **90°** :

Position de repos-Sortie centrale

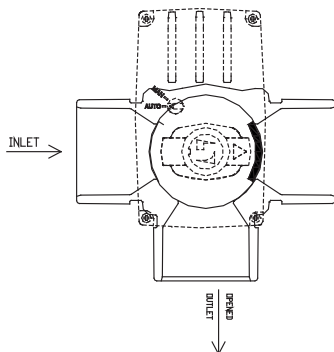

Position 90°-Sortie droite

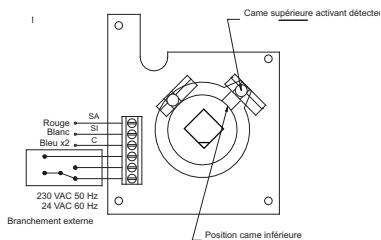
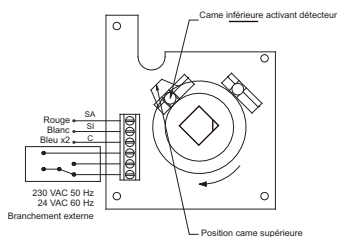
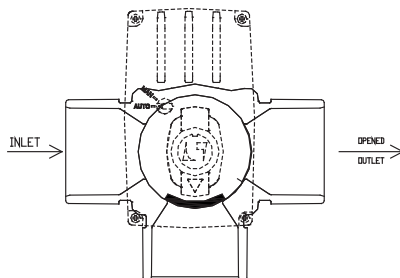

Pour changer la configuration du sens de rotation, consulter le fabricant.

### 3. Fonctionnement

L'automatisme provoque la rotation de l'axe de sortie de l'actionneur de 90° ou de 180°, dépendant de la position des deux cames internes. De plus, les cames peuvent être positionnées de façon que la position d'arrêt soit de 15 ou 30° antérieur ou postérieur à la position de vanne fermée ou ouverte.

Pour changer la position des cames, il faut démonter la manette et le couvercle afin de pouvoir accéder aux deux cames. Ces dernières peuvent être soulevées et mises dans la nouvelle position en faisant coïncider les rainures des cames avec la saillie de l'axe principal. Il est conseillé que la configuration des cames soit effectuée par le fabricant.

**4. Commande manuelle de secours**

Utiliser seulement en cas de défaillance de l'actionnement automatique.

Pour l'actionnement manuel de l'actionneur, il faut appuyer sur le sélecteur MAN/AUTO et, pendant que l'on maintient la pression sur celui-ci, il faut tourner le sélecteur de manière qu'il soit positionné vers le symbole MAN. Ainsi, on pourra tourner la manette indicatrice manuellement jusqu'à la position souhaitée.

Il est impératif que appuyant sur l'interrupteur manuel / automatique du moteur est arrêté pour éviter d'endommager les engrenages.

Il est conseillé de tenir l'interrupteur manuel / automatique tandis que la poignée est tournée manuellement pour empêcher tout contact entre les engrenages.

Pour revenir en mode automatique, mettez le manuel / automatique à la position automatique; petit tour de la position de la manette permettra de s'assurer que le commutateur manuel /auto est de retour à sa position de départ (en relief) en raison du ressort interne.

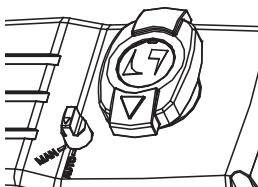

**5. Composants**

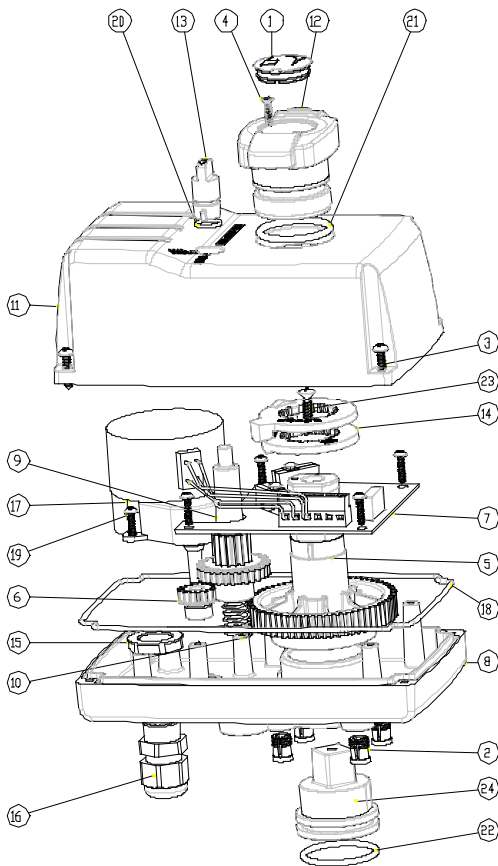

N	CODE	DENOMINATION	MATERIAU	Q
1	058107506	Bouchon	PP	1
2	607305016	Insert	Brass	4
3	711435016	Vis	Inox	4
4	711429013	Vis	Inox	1
5	05907303001	Roue dentée	POM	1
6	05907303002	Pignon moteur	POM	1
7	05907303003	Plaque électronique	-	1
8	05907303004	Base	ASA	1
9	05907303005	Pignon double	POM	1
10	05907303006	Ressort	Inox	1
11	05907303007	Couvercle	-	1
12	05907303008	Manette indicatrice	PP	1
13	05907303009	Sélecteur manuel	PP	1
14	05907303010	Cam	POM	2
15	05907303011	Écrou presse-étoupe	PA	1
16	05907303012	Présse-étoupe	PA	1
17	05907303013	Motoréducteur	-	1
18	05907303015	Joint couvercle	Rubber	1
19	711529013	Screw	Inox	6
20	8070091016	Joint torique	EPDM	1
21	8070280030	Joint torique	EPDM	1
22	8070298026	Joint torique	EPDM	1
23	711539019	Screw	Inox	1
24	05907303021	Couplage	POM	1

6. Vanne d'arrêt rotative à 3 voies motorisée

D63

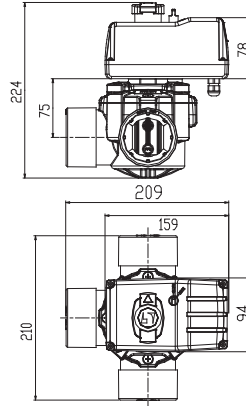
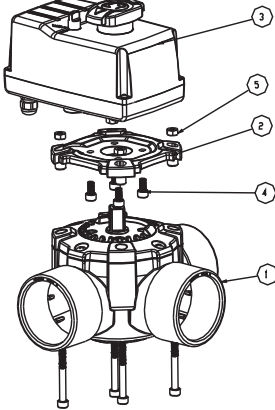

N	CODE	DENOMINATION	MATERIAU	Q
1	0590740X	Vanne d'arrêt rotative sans manette	-	1
2	059074020	Support motorisation	PVC-U	1
3	059073030 05907303A24	Actionneur électrique	-	1
4	710706012	Vis	Inox	4
5	71206000	Écrou	Inox	4
6	710706045	Vis	Inox	4

D50

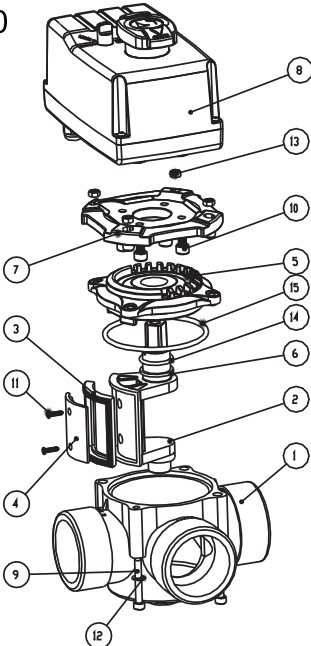

N	CODE	DENOMINACIÓN	MATERIAL	Q
1	059073000	Corps	PVC-U	1
2	059073011	Écluse	PPO	1
3	059072035	Joint du sél. du débit	Silicone	1
4	059072002	Support joint	PPO	1
5	059073013	Couvercle	PPO	1
6	059072015	Joint plat	PTFE	
7	059073020	Support motorisation D50	PVC-U	1
8	059073030 05907303A24	Actionneur électrique	-	1
9	710705060	Vis	Inox	4
10	710706012	Vis	Inox	4
11	711429013	Vis	Inox	2
12	711905000	Rondelle	Inox	4
13	712105000	Écrou	Inox	4
14	8070219026	O-ring	EPDM	1
15	8070758035	O-ring	EPDM	1

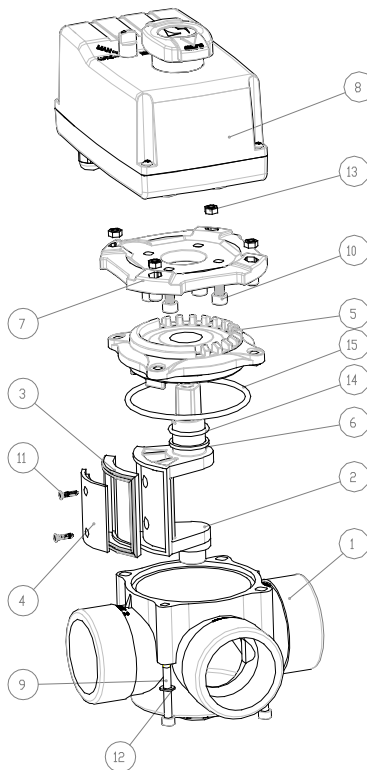

**7. Solution aux problèmes éventuels**

PROBLEME	MOTIF	SOLUTION
La vanne ne tourne pas dans le sens souhaité	Mauvais branchement	Changer le câble blanc par le rouge dans le branchement du moteur et les deux câbles de branchement du relais entre eux
La vanne tourne bien dans le sens souhaité mais ne s'arrête pas sur la position requise	La position des cames n'est pas correcte	Extraire la manette, ôter le couvercle et changer la position des cames suivant la description du manuel
	Le branchement du relais est inversé	Inverser les câbles de branchement du relais de changement de sens (marron-noir).
	L'un des détecteurs ne fonctionne pas	Il faudra changer la plaque électronique. Contacter le distributeur
Il est impossible d'effectuer la rotation manuelle de la vanne	L'engrenage intermédiaire n'a pas été entièrement libéré du moteur	Le sélecteur manuel/auto doit être enfoncé et tourné vers la position manuelle
En passant la vanne de manuel à automatique, l'automatisme ne fonctionne pas	Le sélecteur manuel/auto n'est pas monté en effectuant le changement de position	S'assurer que le sélecteur revienne à la position supérieure en déplaçant légèrement la manette principale afin de libérer la roue dentée

**ÍNDICE**

- 0. Advertencias ..... 13
- 1. Características técnicas ..... 13
- 2. Conexión eléctrica ..... 14
- 3. Funcionamiento ..... 16
- 4. Accionamiento manual ..... 16
- 5. Componentes ..... 16
- 6. Válvula de compuerta rotatoria 3 vías motorizada ..... 17
- 7. Solución de posibles problemas ..... 17

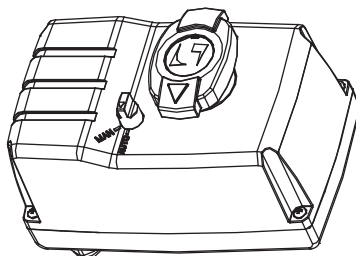

**0. Advertencias**

- o Leer estas instrucciones antes de conectar el actuador y seguir las recomendaciones aquí mencionadas. Los daños causados por no seguir estas instrucciones no estarán cubiertos por la garantía.
- o Las operaciones de conexión y manipulación deberán ser realizadas por personal cualificado.
- o Cortar la alimentación antes de abrir la cubierta.
- o Máxima vida útil: 5.000 maniobras - 180°.
- o Es recomendable proteger el aparato con fusibles independientes o protecciones eléctricas adecuadas.
- o No dejar objetos en el interior que puedan dañar el mecanismo.
- o Prestar especial atención a que no entre agua en el interior de la carcasa.
- o No es recomendable su instalación a la intemperie.
- o Antes de cambiar la posición de la válvula detenga siempre la bomba.

**1. Características técnicas**

- o Par nominal de salida = 4,25 N•m
- o Velocidad de giro de salida = 0,6 min<sup>-1</sup>
- o Potencia = 5 W.
- o Tiempo de giro de 90° = 26 s (180° - 52 s).
- o Grado de protección: IP65
- o Rango de temperatura: 0 – 45 °C.
- o Peso: 1,2 kg
- o Fijación según ISO 5211 ø50 F05

Dos configuraciones eléctricas posibles:

- 230 Vac / 50-60 Hz.
- 24 Vac / 50-60 Hz.

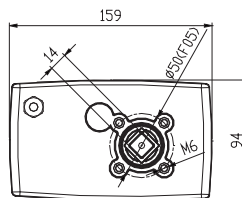
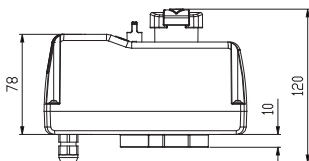

2. Conexión eléctrica

La válvula se suministra con un cable de 4 hilos x 1 mm<sup>2</sup>. Conectar según el esquema impreso en la cubierta del actuador. El dibujo indica el conexionado externo: un relé exterior debe realizar el cambio de sentido de giro, conmutando la señal del cable negro al cable marrón.

Para cambiar el conexionado eléctrico de la válvula es necesario extraer la maneta indicadora y desmontar la tapa del accionamiento para acceder a la regleta de conexión. Pasar un cable de 4 hilos por el pasacables inferior hasta la regleta mostrada en el dibujo.

Conexión externa

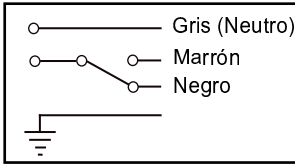

Conexión cable 3 hilos

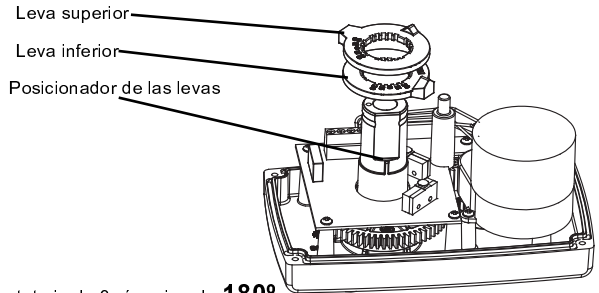
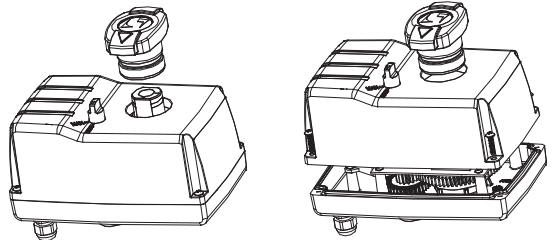
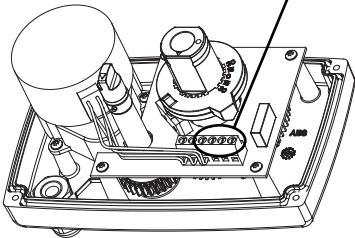

Configuración de levas para la válvula de compuerta rotatoria de 3 vías girando **180°**.

Posición reposo - Salida derecha

Posición 180° - Salida izquierda

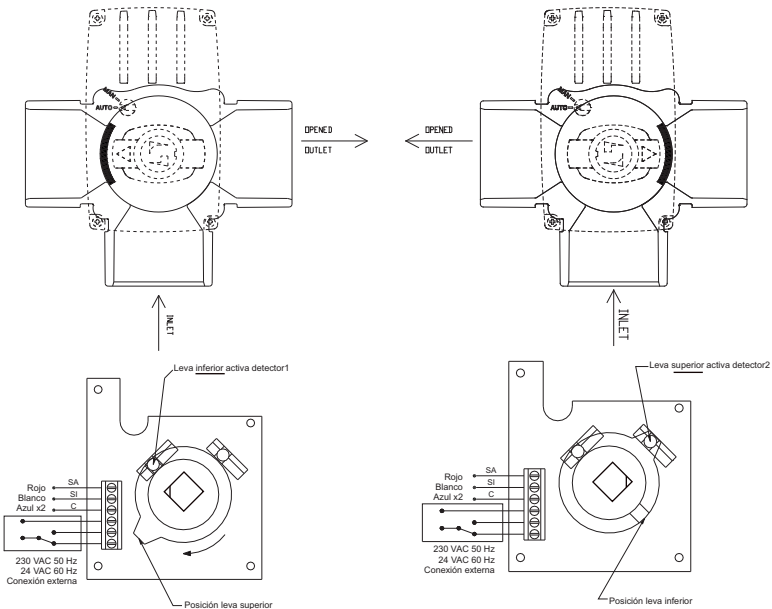



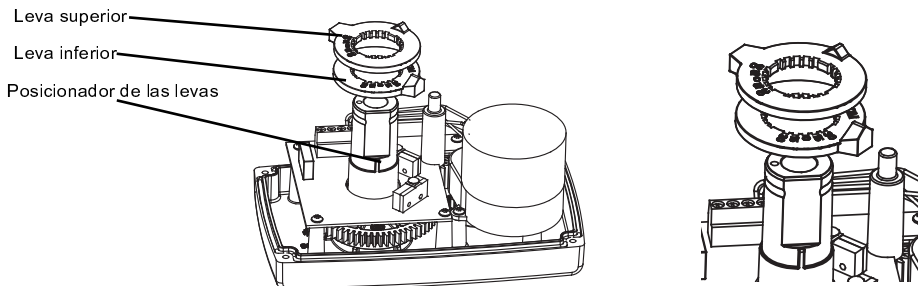

Configuración de levas para la válvula de compuerta rotatoria de 3 vías girando **90°**:

Posición Reposo - Salida central

Posición 90° - Salida derecha

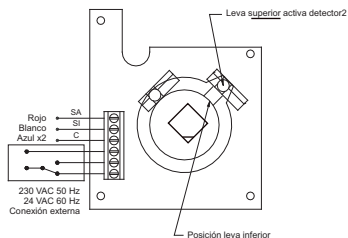
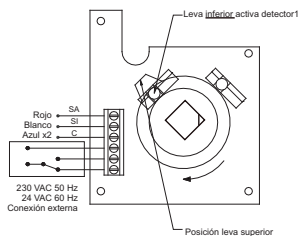
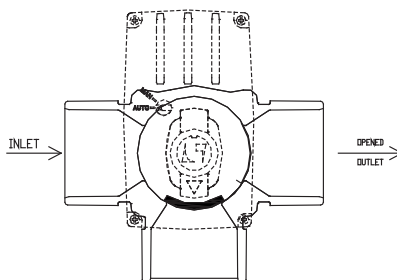
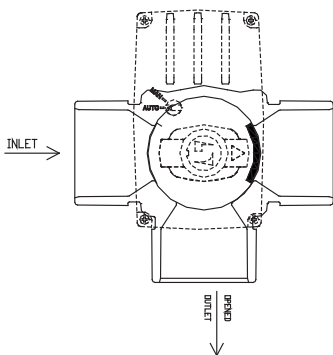

Para cambiar la configuración del sentido de giro consultar al fabricante.

### 3. Funcionamiento

El automatismo provoca el giro automático del eje de salida del actuador en 90° o de 180°, dependiendo de la posición de las dos levas internas. Además, las levas se pueden posicionar de forma que la posición de paro sea 15 ó 30° anterior o posterior a la posición de válvula cerrada o abierta.

Para cambiar la posición de las levas, es necesario desmontar la maneta y la tapa para poder acceder a las dos levas. Éstas pueden levantarse y colocarlas en la nueva posición, haciendo coincidir las ranuras de las levas con el resalte del eje principal.

Es recomendable que la configuración de las levas se realice por parte del fabricante.

**4. Mando de emergencia manual**

Utilizar solo en caso de fallo del accionamiento eléctrico.

Para el accionamiento manual del actuador, es necesario presionar el selector MAN / AUTO y, mientras se mantiene presionado, girar el selector de manera que señale hacia el símbolo MAN. De esta forma, se podrá girar manualmente la maneta indicadora hasta la posición deseada.

Es imprescindible que al presionar el selector manual/auto el motor esté parado para evitar daños en los piñones.

Es aconsejable mantener pulsado el selector manual / automático mientras se gira la maneta de forma manual para evitar el contacto entre los piñones.

Para volver al funcionamiento automático, coloque el selector manual / auto a la posición auto; de pequeños giros a la maneta de posición hasta asegurarse que el selector manual/auto ha vuelto a su posición inicial (levantada) por efecto del muelle interno.

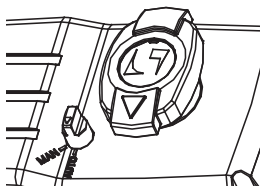

**5. Componentes**

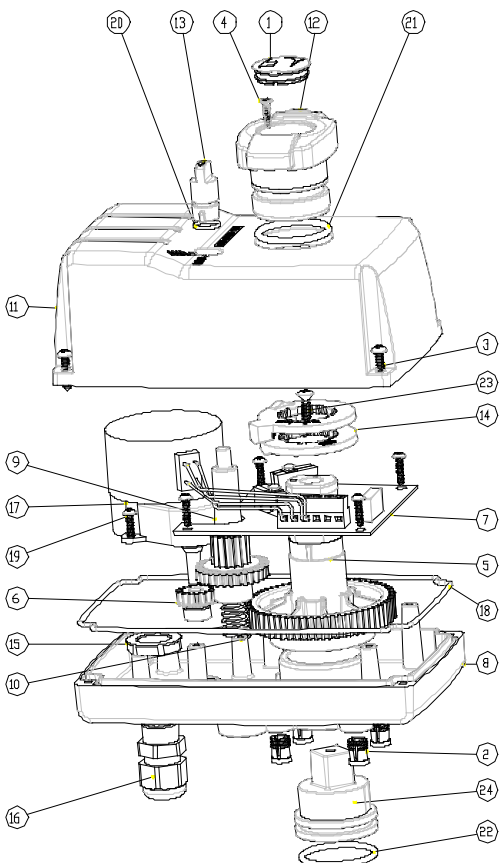

N	CODE	DENOMINACIÓN	MATERIAL	Q
1	058107506	Tapón	PP	1
2	607305016	Inserto	Brass	4
3	711435016	Tornillo	Inox	4
4	711429013	Tornillo	Inox	1
5	05907303001	Rueda dentada	POM	1
6	05907303002	Piñón motor	POM	1
7	05907303003	Placa electrónica	-	1
8	05907303004	Base	ASA	1
9	05907303005	Piñón doble	POM	1
10	05907303006	Muelle	Inox	1
11	05907303007	Tapa	-	1
12	05907303008	Maneta indicadora	PP	1
13	05907303009	Selector manual	PP	1
14	05907303010	Leva	POM	2
15	05907303011	Tuerca prensastopas	PA	1
16	05907303012	Prensastopas	PA	1
17	05907303013	Motorreductor	-	1
18	05907303015	Junta tapa	Goma	2
19	711529013	Tornillo	Inox	6
20	8070091016	Junta tórica	EPDM	1
21	8070280030	Junta tórica	EPDM	1
22	8070298026	Junta tórica	EPDM	1
23	711539019	Screw	Inox	1
24	05907303021	Acoplamiento	POM	1

6. Válvula de compuerta rotatoria 3 vías motorizada

D63

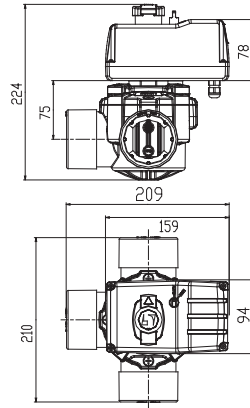
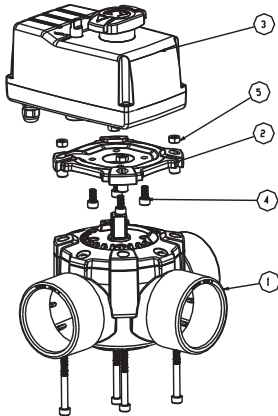

N	CODE	DENOMINACIÓN	MATERIAL	Q
1	0590740X	Válvula compuerta rotatoria sin maneta	-	1
2	059074020	Plataforma motorización D63	PVC-U	1
3	059073030 05907303A24	Actuador eléctrico	-	1
4	710706012	Tornillo	Inox	4
5	71206000	Tuerca	Inox	4
6	710706045	Tornillo	Inox	4

D50

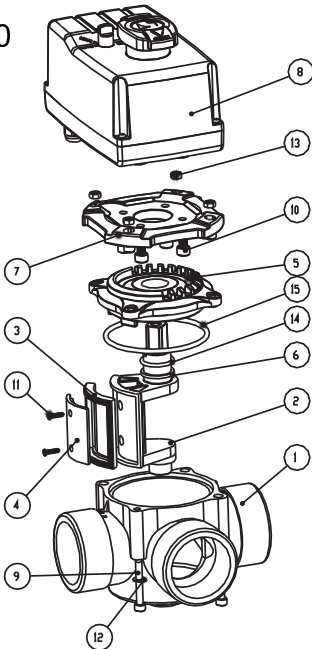

N	CODE	DENOMINACIÓN	MATERIAL	Q
1	059073000	Cuerpo	PVC-U	1
2	059073011	Compuerta	PPO	1
3	059072035	Junta compuerta	Silicona	1
4	059072002	Soporte junta	PPO	1
5	059073013	Tapa	PPO	1
6	059072015	Junta plana	PTFE	
7	059073020	Plataforma motorización D50	PVC-U	1
8	059073030 05907303A24	Actuador eléctrico	-	1
9	710705060	Tornillo	Inox	4
10	710706012	Tornillo	Inox	4
11	711429013	Tornillo	Inox	2
12	711905000	Arandela	Inox	4
13	712105000	Tuerca	Inox	4
14	8070219026	Junta tórica	EPDM	1
15	8070758035	Junta tórica	EPDM	1

D50

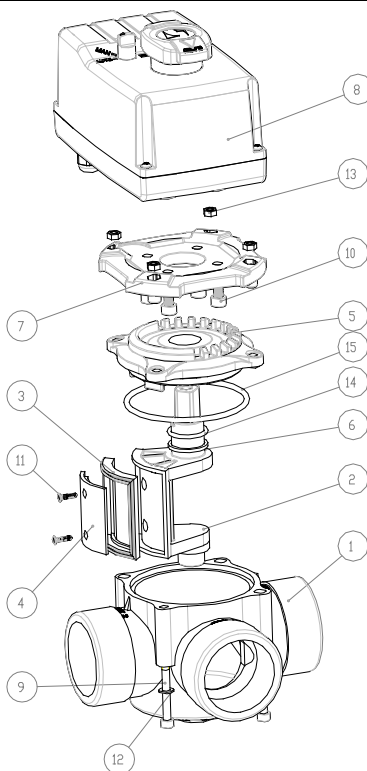

**7. Solución de posibles problemas**

<b>PROBLEMA</b>	<b>CAUSA</b>	<b>SOLUCIÓN</b>
La válvula no gira en el sentido deseado	Conexión errónea	Cambiar el cable blanco por el rojo en la conexión del motor y los dos cables de conexionado del relé entre ellos
La válvula sí que gira en el sentido deseado pero no se para en la posición requerida	La posición de las levas no es correcta	Extraer la maneta, desmontar la tapa y cambiar la posición de las levas según descripción del manual
	La conexión del relé está invertida	Invertir los cables de conexión del relé de cambio de sentido (negro-marrón).
	Alguno de los detectores no funciona	Se deberá cambiar la placa electrónica. Contactar con el distribuidor
No es posible realizar el giro manual de la válvula	El engranaje intermedio no ha quedado liberado totalmente del motor	El selector manual/auto debe estar hundido y girado a la posición manual
Al pasar la válvula de manual a automático el automatismo no funciona	El selector manual/auto no ha subido al realizar el cambio de posición	Asegurar que el selector regresa a la posición superior moviendo ligeramente la maneta principal para facilitar el engrane

**ÍNDICE**

0. Avisos ..... 18  
 1. Características técnicas ..... 18  
 2. Ligação eléctrica ..... 19  
 3. Funcionamento ..... 21  
 4. Accionamento manual ..... 21  
 5. Componentes ..... 21  
 6. Válvula de comporta rotativa de 3 vias motorizada ..... 22  
 7. Solução de possíveis problemas ..... 22

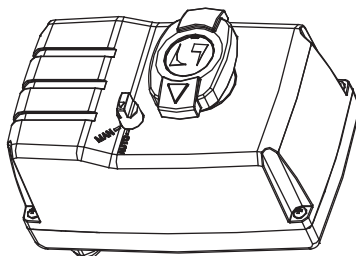

**0. Avisos**

- o Ler estas instruções antes de ligar o actuador e seguir as recomendações aqui mencionadas. Os danos causados por incumprimento destas instruções não estão abrangidos pela garantia.
- o As operações de ligação e manipulação devem ser efectuadas por pessoal qualificado.
- o Cortar a alimentação antes de abrir a tampa.
- o Máxima vida útil: 5.000 manobras - 180°.
- o Recomenda-se proteger o aparelho com fusíveis independentes ou protecções eléctricas adequadas.
- o Não deixar objectos no interior que possam danificar o mecanismo.
- o Prestar especial atenção para que não entre água no interior da carcaça.
- o Não é recomendável a sua instalação ao ar livre.
- o Antes de alterar a posição da válvula pare sempre a bomba.

**1. Características técnicas**

- o Binário nominal de saída = 4,25 N\*m
- o Velocidade de rotação de saída = 0,6 min-1
- o Potência = 5 W.
- o Tempo de rotação de 90° = 26 s (180° - 52 s).
- o Grau de protecção: IP65
- o Intervalo de temperatura: 0 – 45 °C.
- o Peso: 1,2 kg
- o Fixação de acordo com ISO 5211 ø50 F05

Duas configurações eléctricas possíveis:

- 230 Vac / 50-60 Hz.
- 24 Vac / 50-60 Hz.

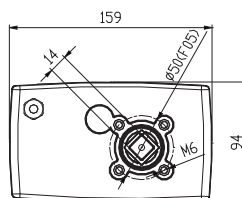
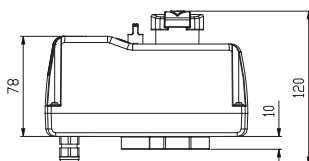

**2. Ligação eléctrica**

A válvula vem acompanhada de um cabo de 4 fios x 1 mm<sup>2</sup>. Ligar de acordo com o esquema impresso na tampa do actuador. O desenho mostra as conexões externas: um relé externo deve alterar o sentido de rotação, o sinal de cabo de comutação preto ao fio marrom.

Para mudar a ligação eléctrica da válvula é necessário retirar a alavanca indicadora e desmontar a tampa do accionamento para poder alcançar o bloco de ligação. Passar um cabo de 4 fios pelo passa-cabos inferior até ao bloco indicado no desenho.

*Ligação exterior*

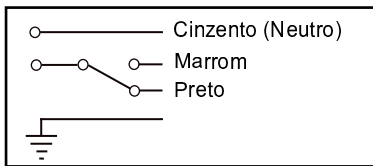

Ligação cabo de 3 fios

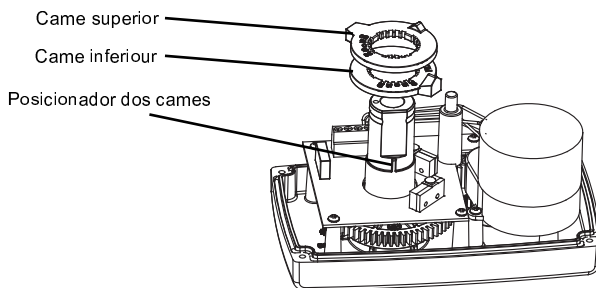
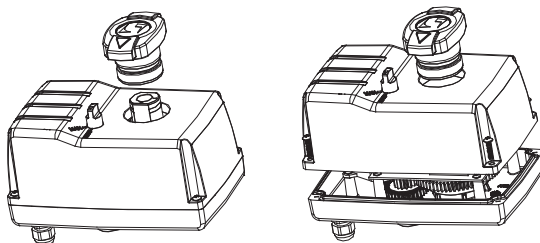
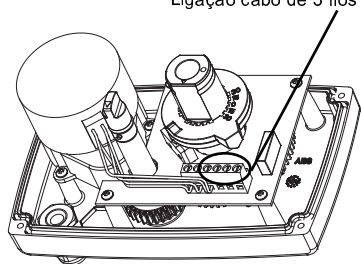

Configuração de cames para a válvula de comporta rotativa de 3 vias girando **180°**:

Posição de repouso-Saída direita

Posição 180°-Saída esquerda

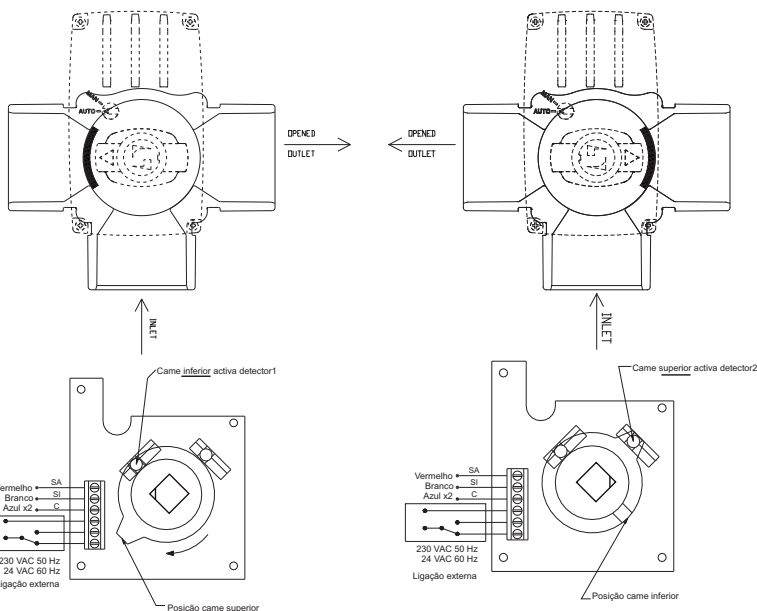

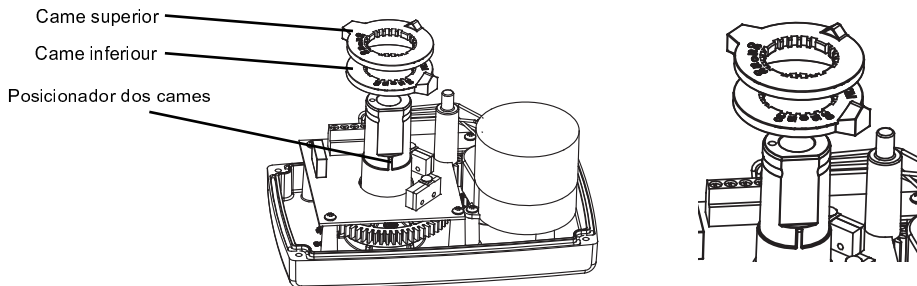

Configuração de cames para a válvula de comporta rotativa de 3 vias girando **90°**.

Posição de repouso-Saída centro

Posição 90°-Saída direita

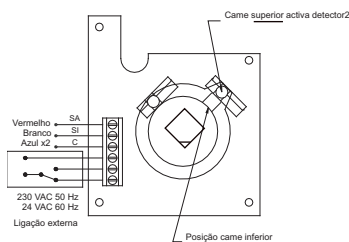
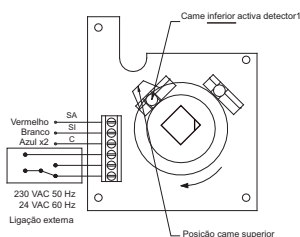
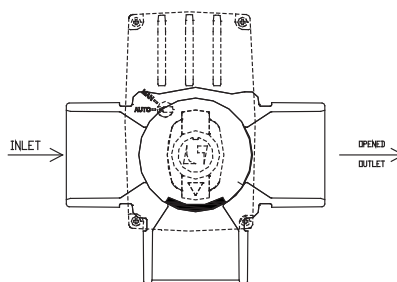
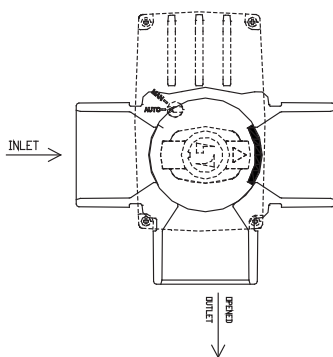

Para alterar a configuração do sentido da rotação deve-se consultar o fabricante.

### 3. Funcionamento

O automatismo provoca a rotação automática do eixo de saída do actuador em 90° ou 180°, dependendo da posição dos dois cames internos. Para além disto, os cames podem ser colocados de forma a que a posição de paragem seja 15 ou 30° antes ou depois da posição da válvula aberta ou fechada.

Para alterar a posição dos cames, é necessário desmontar a alavanca e a tampa para poder chegar aos dois cames. Estes podem ser levantados e colocados na nova posição, fazendo coincidir as ranhuras dos cames com a saliência do eixo principal.

É recomendável que a configuração dos cames seja efectuada pelo fabricante.

**4. Comando manual de emergência**

Utilizar apenas no caso de falha no accionamento automático.

Para o accionamento manual do actuador, é necessário pressionar o selector MAN/AUTO e, enquanto se mantém pressionado, rodar o selector de forma a que aponte para o símbolo MAN. Desta forma, poder-se-á rodar manualmente a alavanca indicadora até à posição desejada.

É imperativo que quando você pressiona o selector manual / auto o motor é interrompido para evitar danos a coroa.

É aconselhável manter o selector manual/auto, enquanto o manípulo é girado manualmente para evitar o contato entre as engrenagens.

Para retornar para o modo automático, rode o manual / auto para a posição auto; pequeno vira a alavanca vai ajudar a garantir que o interruptor manual/auto está de volta à sua posição inicial (para cima) devido à mola interna.

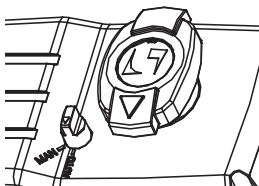

**5. Componentes**

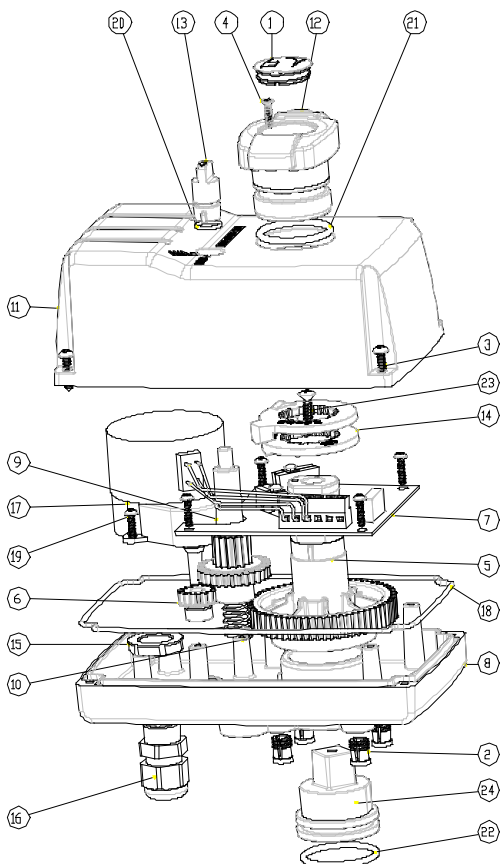

N	CODE	DENOMINAÇÃO	MATERIAL	Q
1	058107506	Tampa	PP	1
2	607305016	Encaixe	Brass	4
3	711435016	Parafuso	Inox	4
4	711429013	Parafuso	Inox	1
5	05907303001	Roda dentada	POM	1
6	05907303002	Carreto motor	POM	1
7	05907303003	Placa electrónica	-	1
8	05907303004	Base	ASA	1
9	05907303005	Carreto duplo	POM	1
10	05907303006	Mola	Inox	1
11	05907303007	Tampa	-	1
12	05907303008	Alavanca indicadora	PP	1
13	05907303009	Selector manual	PP	1
14	05907303010	Came	POM	2
15	05907303011	Porca bucins	PA	1
16	05907303012	Bucins	PA	1
17	05907303013	Motorreductor	-	1
18	05907303015	Junta tampa	Rubber	1
19	711529013	Parafuso	Inox	6
20	8070091016	Junta tórica	EPDM	1
21	8070280030	Junta tórica	EPDM	1
22	8070298026	Junta tórica	EPDM	1
23	711539019	Parafuso	Inox	1
24	05907303021	Acoplamento	POM	1



6. Válvula de comporta rotativa de 3 vias motorizada

D63

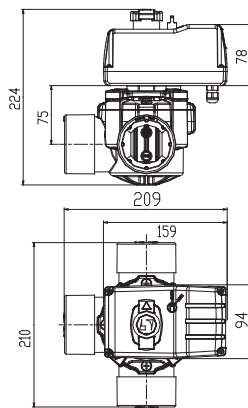
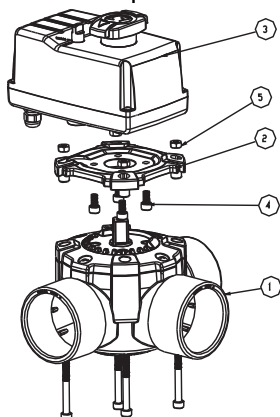

N	CODE	DENOMINAÇÃO	MATERIAL	Q
1	0590740X	Válvula de comporta rotativa sem alavanca	-	1
2	059074020	Suporte motorização	PVC-U	1
3	059073030 05907303A24	Actuador eléctrico	-	1
4	710706012	Parafuso	Inox	4
5	71206000	Porca	Inox	4
6	710706045	Parafuso	Inox	4

D50

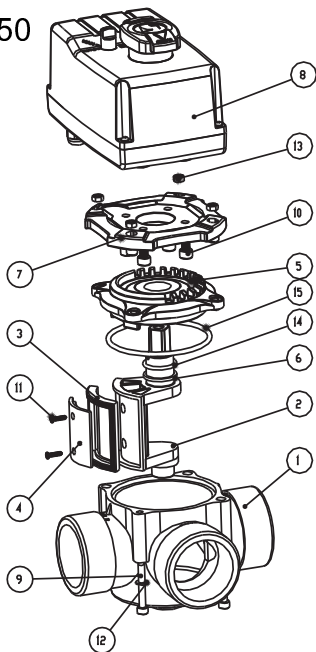

N	CODE	DENOMINAÇÃO	MATERIAL	Q
1	059073000	Corpo	PVC-U	1
2	059073011	Comporta	PPO	1
3	059072035	Junta comporta	Silicona	1
4	059072002	Soporte junta	PPO	1
5	059073013	Tampa	PPO	1
6	059072015	Junta plana	PTFE	
7	059073020	Suporte motorização D50	PVC-U	1
8	059073030 05907303A24	Actuador eléctrico	-	1
9	710705060	Parafuso	Inox	4
10	710706012	Parafuso	Inox	4
11	711429013	Parafuso	Inox	2
12	711905000	Arandela	Inox	4
13	712105000	Porca	Inox	4
14	8070219026	Junta tórica	EPDM	1
15	8070758035	Junta tórica	EPDM	1

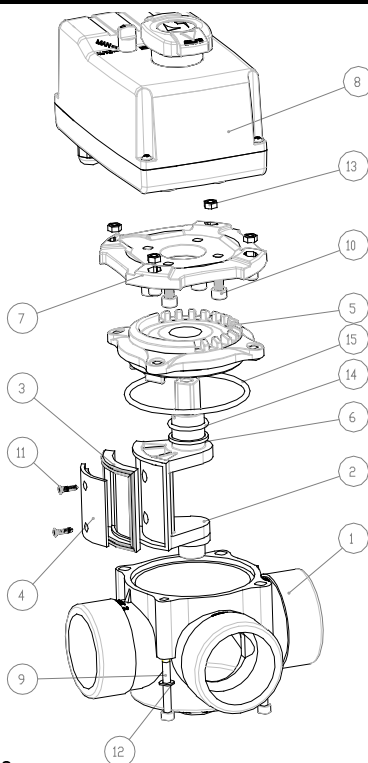

**7. Solução de possíveis problemas**

<b>PROBLEMA</b>	<b>CAUSA</b>	<b>SOLUÇÃO</b>
A válvula não gira no sentido desejado	Ligação errada	Trocar o cabo branco pelo vermelho na ligação do motor e os dois cabos de ligação do relé entre eles
A válvula roda para o sentido desejado mas não pára na posição desejada	A posição dos cames não é a correcta	Retirar a alavanca, desmontar a tampa e mudar a posição dos cames de acordo com a descrição do manual
	A ligação do relé está invertida	Inverter os cabos de ligação do relé de alteração de sentido (marrom-preto).
	Algum dos detectores não funciona	Deve-se mudar a placa electrónica. Contactar o distribuidor
Não é possível fazer a rotação manual da válvula	A engrenagem intermédia não ficou totalmente liberta do motor	O selector manual/auto deve estar metido para dentro e virado para a posição manual
Ao passar a válvula de manual para automática o automatismo não funciona	O selector manual/auto não subiu ao alterar a posição	Verificar que o selector regressa à posição superior movendo ligeiramente a alavanca principal para facilitar o engrenamento

## ÍNDICE

0.	Avvertenze .....	23
1.	Caratteristiche tecniche .....	23
2.	Connessione/collegamento elettrico .....	24
3.	Funzionamento .....	26
4.	Azionamento manuale .....	26
5.	Componenti .....	26
6.	Valvola rotante a farfalla 3 vie motorizzata.....	27
7.	Soluzione di eventuali problemi .....	27

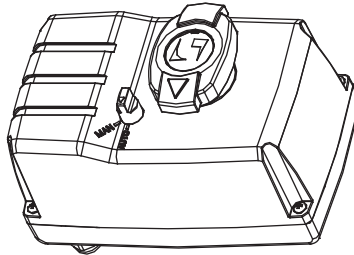

### 0. Avvertenze

- o Leggere queste istruzioni prima di collegare l'attuatore e continuare a seguire le raccomandazioni qui menzionate. Gli eventuali danni causati dalla mancata lettura ed esecuzione delle presenti istruzioni non sono coperti da garanzia.
- o Le operazioni di collegamento e manipolazione dovranno essere realizzate da personale specializzato e qualificato.
- o Scollegare l'alimentazione elettrica prima di aprire il coperchio.
- o Testato per: 5.000 manovre - 180°.
- o Si raccomanda di proteggere l'apparecchio con fusibili indipendenti o protezioni elettriche adeguate.
- o Evitare di lasciare oggetti all'interno che possano danneggiare il meccanismo.
- o Evitare che entri acqua all'interno della carcassa, prestare particolare attenzione.
- o Si consiglia di non effettuare l'installazione alle intemperie.
- o Arrestare sempre la pompa prima di cambiare la posizione della valvola.

### 1. Caratteristiche tecniche

- o Par nominale d'uscita = 4,25 N•m
- o Velocità di giro d'uscita = 0,6 min<sup>-1</sup>
- o Potenza = 5 W.
- o Tempo di giro de 90° = 26 s (180° - 52 s).
- o Grado di protezione: IP65
- o Rango di temperatura: 0 - 45 °C.
- o Peso: 1,2 kg
- o Fissaggio secondo ISO 5211 ø50 F05

Due configurazioni elettriche possibili:

- 230 Vac / 50-60 Hz.
- 24 Vac / 50-60 Hz.

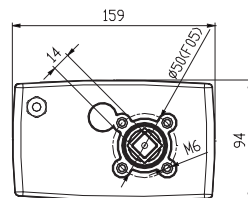
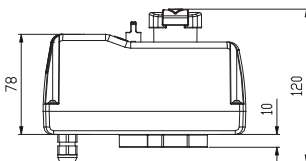

**2. Connessione elettrica**

La valvola è dotata di un cavo d'alimentazione da 4 fili x 1 mm<sup>2</sup>. Collegare seguendo lo schema presente sul coperchio dell'attuatore. Il disegno mostra le connessioni esterne: un relè esterno deve cambiare la direzione di rotazione, il segnale via cavo di commutazione nero sul filo marrone. Per modificare il collegamento della valvola all'alimentazione elettrica è necessario estrarre la maniglia con indicatore e smontare il coperchio dell'apparato di azionamento per accedere alla multipresa di connessione. Far passare un cavo a 4 fili attraverso il passacavi inferiore fino alla multipresa come indicato nel disegno.

Connessione esterne

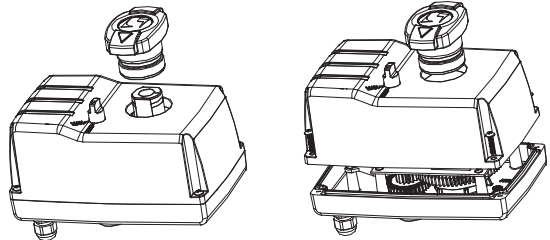
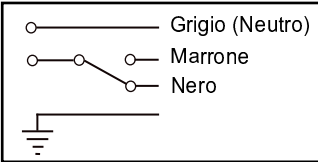

Connessione / collegamento cavo a 3 fili

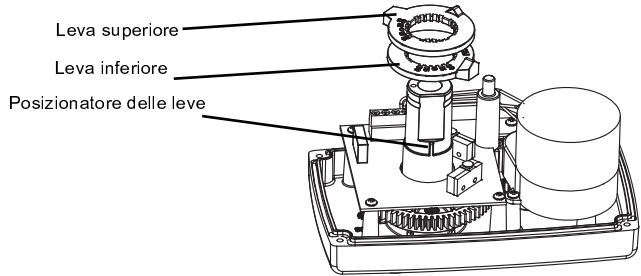
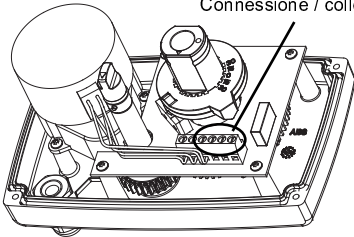

Configurazione delle leve per valvola rotante a farfalla a 3 vie, angolo di rotazione di **180°**:

Posizione di riposo-Uscita a destra

Posizione 180°-Uscita sinistra

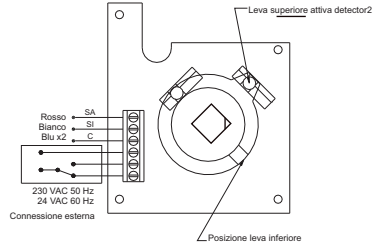
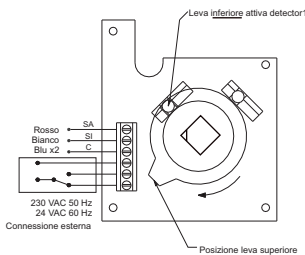
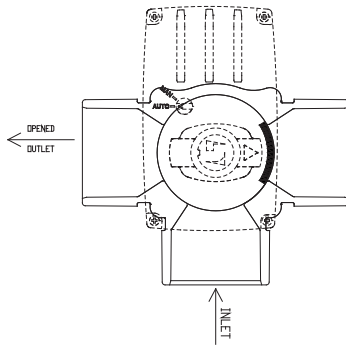
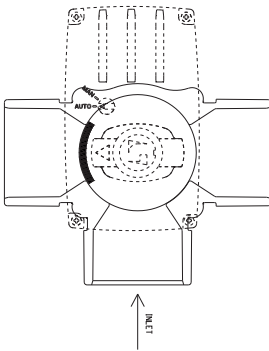

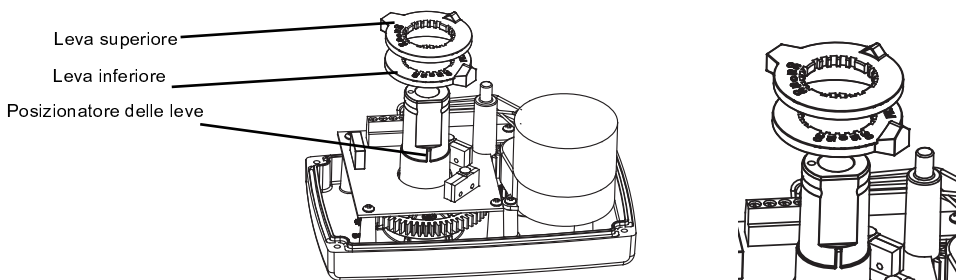

Configurazione per valvola rotante a farfalla a 3 vie, angolo di rotazione di **90°**:

Posizione di riposo-Uscita centro

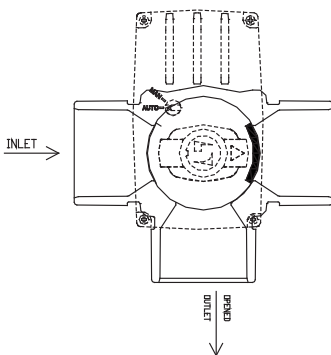

Posizione 90°-Uscita a destra

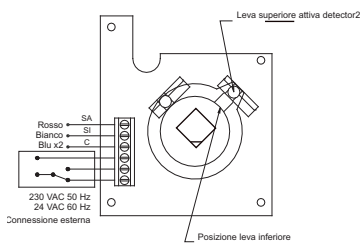
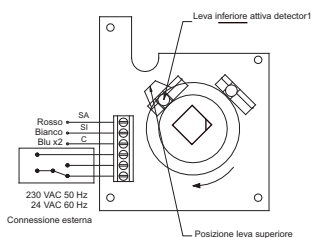
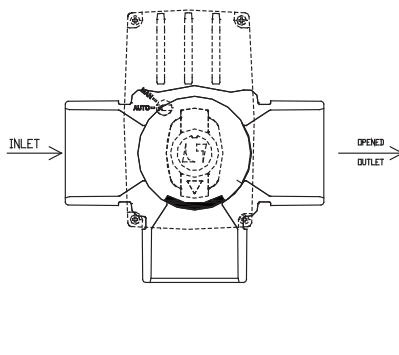

Per cambiare la configurazione del senso di rotazione consultare il fabbricante.

### 3. Funzionamento

L'automatismo provoca la rotazione automatica dell'asse d'uscita dell'attuatore con angolo di rotazione di 90° o di 180°, dipendendo dalla posizione delle due leve interne. Inoltre le leve possono essere collocate in modo che la posizione di arresto sia 15° o 30° anteriore o posteriore alla posizione di valvola chiusa o aperta.

Per cambiare la posizione delle leve, è necessario smontare la maniglia e il coperchio per poter accedere alle due leve. Le leve possono essere spostate e collocate nella nuova posizione, facendo coincidere le filettature delle leve con l'incastro dell'asse principale. Si consiglia di far effettuare la configurazione delle leve dal fabbricante.

**4. Comando manuale d'emergenza**

Utilizzare solo in caso di guasto dell'azionamento automatico.

Per l'azionamento manuale dell'attuatore è necessario pressione il selettore MAN / AUTO e, mentre si mantiene la pressione, girare il selettore in modo che sia posizionato verso il simbolo MAN. In questo modo è possibile girare manualmente la maniglia con indicatore nella posizione prescelta.

È imperativo che quando si preme il selettore manuale/auto il motore viene fermato per evitare di danneggiare i denti.

Si consiglia di tenere premuto l'interruttore manuale/auto mentre il manico è acceso manualmente per evitare il contatto tra gli ingranaggi.

Per tornare all'automatica, girare il manuale/auto selettore in posizione auto, piccoli giri la maniglia contribuirà a garantire che l'interruttore manuale / auto è tornato alla sua posizione di partenza (fino) a causa della molla interna.

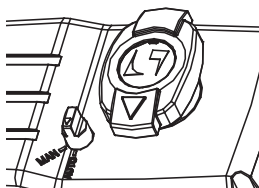

**5. Componenti**

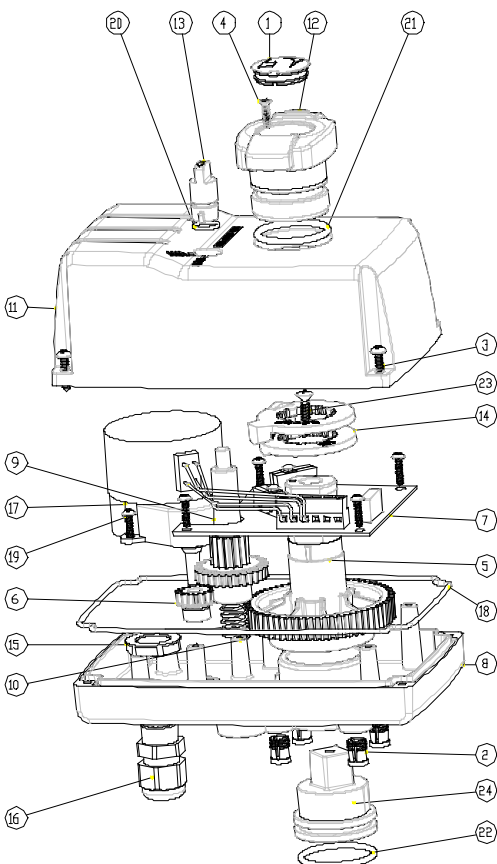

N	CODICE	DENOMINAZIONE	MATERIAL	Q
1	058107506	Tappo	PP	1
2	607305016	Inserto	Brass	4
3	711435016	Vite	Inox	4
4	711429013	Vite	Inox	1
5	05907303001	Ruota dentata	POM	1
6	05907303002	Pignone motore	POM	1
7	05907303003	Pannello elettronico	-	1
8	05907303004	Base	ASA	1
9	05907303005	Pignone doppio	POM	1
10	05907303006	Molla	Inox	1
11	05907303007	Coperchio	-	1
12	05907303008	Maniglia con indicatore	PP	1
13	05907303009	Selettore manuale	PP	1
14	05907303010	Leva	POM	2
15	05907303011	Dado Premistoppa	PA	1
16	05907303012	Premistoppa	PA	1
17	05907303013	Motoriduttore	-	1
18	05907303014	Guarnizione Coperchio	Rubber	1
19	711529013	Vite	Inox	6
20	8070091016	Guarnizione	EPDM	1
21	8070091016	Guarnizione	EPDM	1
22	8070298026	Guarnizione	EPDM	1
23	711539019	Vite	Inox	1
24	05907303021	Accoppiamento	POM	1

## 6. Valvola a farfalla rotante a 3 vie motorizzata

D63

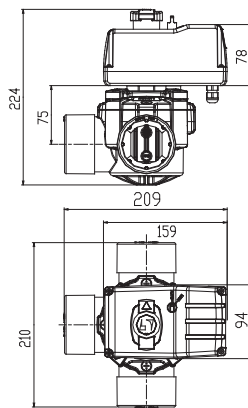
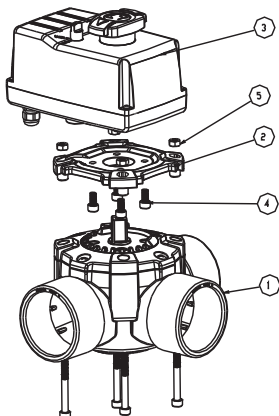

N	CODICE	DENOMINAZIONE	MATERIAL	Q
1	0590740X	Valvola rotante a farfalla senza maniglia	-	1
2	059074020	Supporto motorizzazione Attuatore	PVC-U	1
3	059073030 05907303A24	Attuatore elettrico	-	1
4	710706012	Vite	Inox	4
5	71206000	Dado	Inox	4
6	710706045	Vite	Inox	4

D50

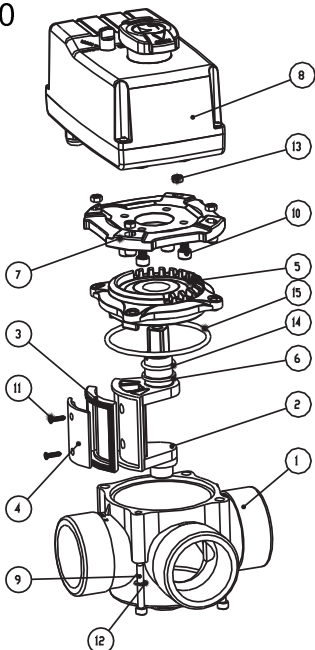

N	CODE	DENOMINAZIÓN	MATERIAL	Q
1	059073000	Corpo	PVC-U	1
2	059073011	Serranda girevole	PPO	1
3	059072035	Guarnizione serranda	Silicona	1
4	059072002	Flangia guarnizione	PPO	1
5	059073013	Coperchio	PPO	1
6	059072015	O-ring asse	PTFE	
7	059073020	Supporto motorizzazione	PVC-U	1
8	059073030 05907303A24	Attuatore elettrico	-	1
9	710705060	Vite	Inox	4
10	710706012	Vite	Inox	4
11	711429013	Vite	Inox	2
12	711905000	Rondella	Inox	4
13	712105000	Dado	Inox	4
14	8070219026	O-ring	EPDM	1
15	8070758035	O-ring	EPDM	1

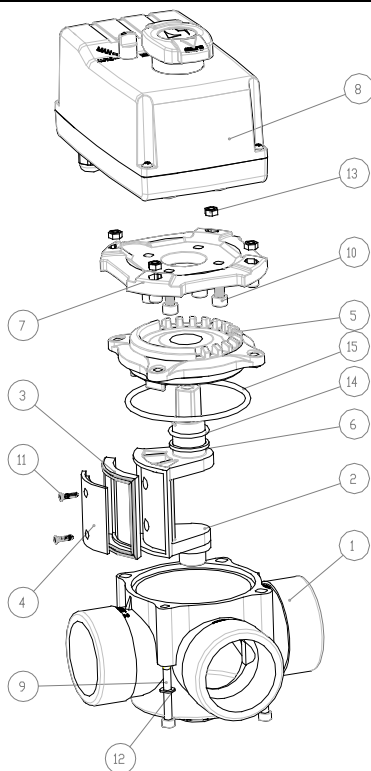

**7. Soluzione di possibili problemi**

<b>PROBLEMA</b>	<b>CAUSA</b>	<b>SOLUZIONE</b>
La valvola non gira nel senso desiderato	Connessione erronea	Sostituire il cavo bianco con quello rosso nella connessione del motore e i due cavi del collegamento del relè fra di essi
La valvola gira in senso prescelto ma non si arresta nella posizione richiesta	La posizione delle leve non è corretta	Estrarre la maniglia, smontare il coperchio e cambiare la posizione delle leve come descritto sul manuale di istruzioni
	La connessione del relè è invertita	Invertire i cavi di connessione del relè del cambio di rotazione (marrone-nero).
	Qualche detector non funziona	Dovrà cambiare il pannello elettronico. Contattare il distributore
Non è possibile realizzare la rotazione manuale della valvola	L'ingranaggio intermedio non è totalmente libero dal motore	Il selettore manuale/auto deve essere situato nella posizione manuale
Passando dal funzionamento manuale a quello automatico l'automatismo non funziona	Durante il cambio di posizione il selettore manuale/auto non si è sollevato	Assicurarsi che il selettore ritorni alla posizione superiore muovendo leggermente la maniglia principale per facilitarne l'ingranaggio



## INHALT

0.	Warnungshinweise .....	28
1.	Technische Eigenschaften .....	28
2.	Elektrischer Anschluss .....	29
3.	Funktionsweise .....	31
4.	Manuelle Steuerung .....	31
5.	Teile .....	31
6.	Automatisches 3-Wege Umschaltventil .....	32
7.	Lösung möglicher Probleme .....	32

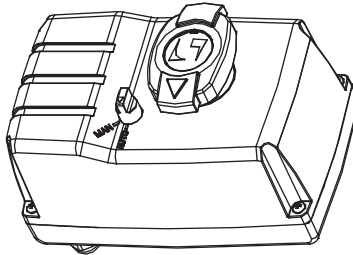

## 0. Warnungshinweise

- o Vor dem Anschluss des Stellantriebs die Anweisungen lesen und die dort genannten Empfehlungen befolgen. Die Garantie haftet nicht für Schäden, die durch Nichtbefolgen der Anweisungen entstanden sind.
- o Der Anschluss und die Inbetriebnahme sollte durch qualifiziertes Personal vorgenommen werden.
- o Vor dem Öffnen der Abdeckung muss der Strom abgeschaltet werden.
- o Maximale Lebensdauer: 5.000 Schaltungen - 180°.
- o Es wird empfohlen, die Anlage durch unabhängige Sicherungen oder angemessene elektrische Schaltungen zu sichern.
- o Keine Objekte im Innern lassen, die den Mechanismus beschädigen könnten.
- o Es muss besonders darauf geachtet werden, dass kein Wasser ins Innere des Gehäuses eindringt.
- o Eine Installation im Freien ist nicht empfehlenswert.
- o Vor einer Veränderung der Position des Ventils muss immer die Pumpe abgeschaltet werden.

## 1. Technische Eigenschaften

- o Ausgangsdrehmoment = 4,25 N·m
- o Geschwindigkeit der Drehung = 0,6 min<sup>-1</sup>
- o Leistung = 5 W.
- o Dauer einer 90°-Drehung = 26 s (180° - 52 s).
- o Schutzart: IP65
- o Temperaturbereich 0 – 45 °C.
- o Gewicht: 1,2 kg
- o Befestigung gemäß ISO 5211 ø50 F05

Zwei mögliche Betriebsspannungen:

- 230 Vac / 50-60 Hz.
- 24 Vac / 50-60 Hz.

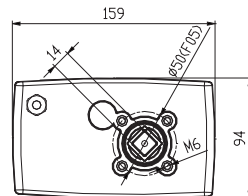
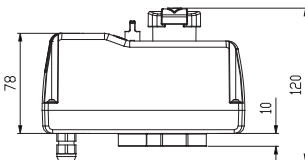

2. Elektrischer Anschluss

Das Ventil wird mit mit 4 Leitungen (je 1 mm<sup>2</sup> Durchmesser). Der Anschluß erfolgt nach dem Schema, welches auf der Kappe des Stellantriebs abgebildet ist. Die Zeichnung zeigt den externen Anschlüssen: ein externes Relais muss die Drehrichtung ändern, das Kabel Signal-Switching-schwarz an braune Ader.

Zu ändern den elektrischen Anschluss des Ventils vornehmen zu können, ist es notwendig, den Anzeihebel abzunehmen und die Verschlusskappe zu demontieren, um an die Schalttafel zu gelangen.

conexión. Wie im Bild dargestellt, wird ein 4-adriges Kabel durch die innere Buchse bis zur Schalttafel geführt.

Externen elektrischen Anschluss

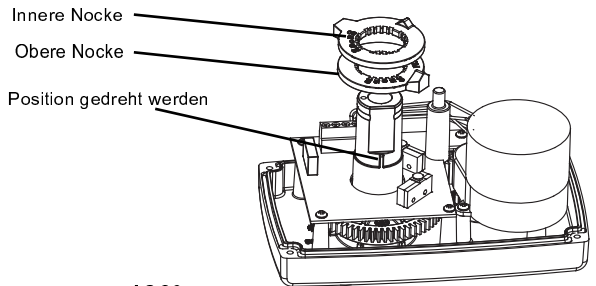
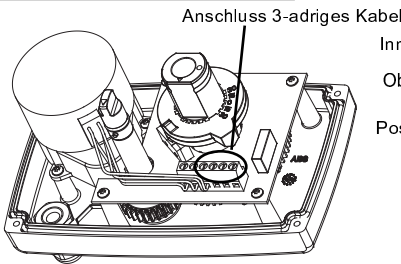
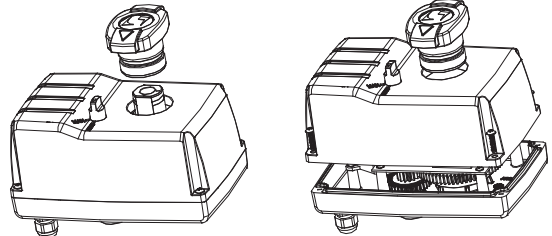
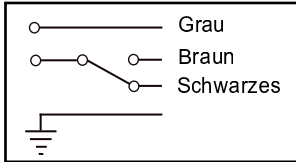

Konfigurierung der Nocken des 3-Wege Umschaltventils bei **180°** Drehung:

Ruhestellung - Ausgang rechts

Position 180° - Linken Ausgang

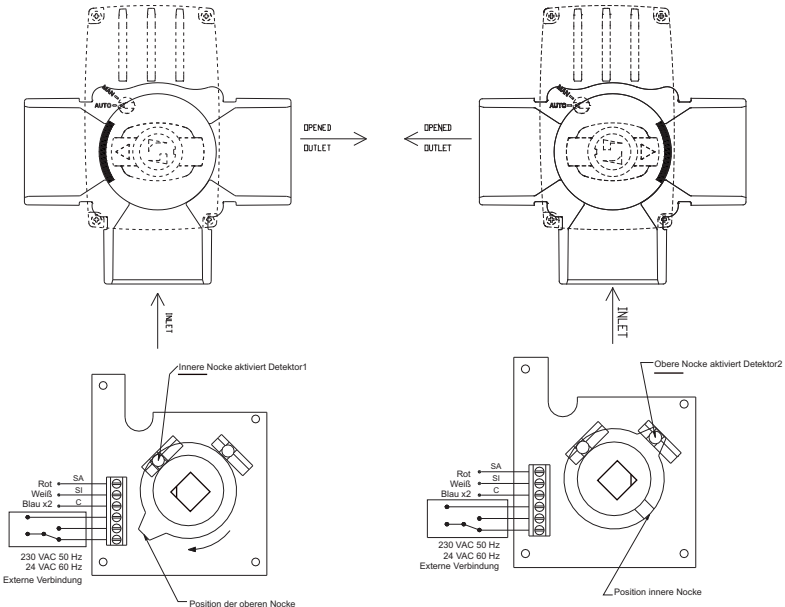

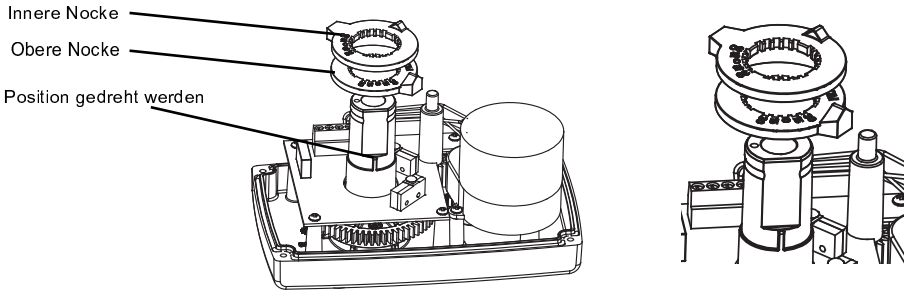

Konfigurierung der Nocken des 3-Wege Umschaltventils bei **90°** Drehung:

Ruhestellung - Center-Ausgang

Position 90° - Ausgang rechts

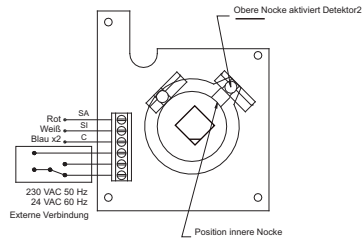
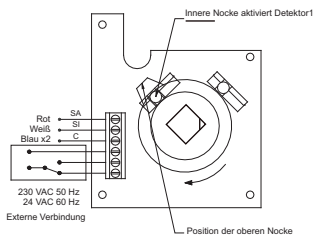
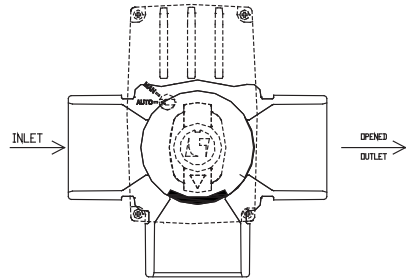
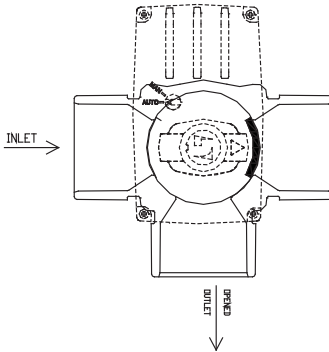

Für die Konfigurierung bei entgegengesetzter Drehrichtung bitte den Hersteller konsultieren.

### 3. Funktionsweise

Die automatische Arbeitsweise proziert die automatische Drehung der Achse des Stellantriebs um 90° oder 180°, je nach Stellung der inneren Nocken.

Weiterhin können die Nocken so gestellt werden, daß das Ventil 15° oder 30° vor oder nach der Position offen oder geschlossen stoppt.

Um die Stellung der Nocken zu verändern, ist es notwendig, den Hebel und die Kappe zu demontieren, um an die Nocken zu kommen.

Die Nocken können angehoben und in die neue Stellung gebracht werden, solange die Nuten der Nocken mit den Stollen der Achse übereinstimmen.

Es ist empfehlenswert, die Konfigurierung der Nocken durch den Hersteller vornehmen zu lassen.

**4. Handsteuerung im Notfall**

Nur im Falle eines Fehlers der Automatik benutzen.

Um den Antrieb manuell zu steuern, ist es notwendig, den Hebel MAN / AUTO nach unten zu drücken, und während des Drückens den Hebel auf das Symbol MAN zu drehen.

Auf diese Weise kann der Hebel manuell auf die gewünschte.

Es ist zwingend notwendig, wenn Sie die manuelle/auto Schalter drücken, der Motor gestoppt ist, um eine Beschädigung der Zähne.

Es ist ratsam, das Handbuch Wählhebel halten, während Sie mit der Hand, den Kontakt zwischen den Gängen zu vermeiden. Um wieder in den automatischen, stellen Sie den Schalter manuell/auto in die automatische Position, dreht kleine den Griff wird sichergestellt, dass der Schalter hat seine Ausgangsposition (up) durch die interne Feder zurück.

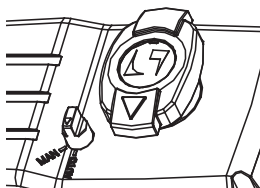

**5. Einzelteile parts**

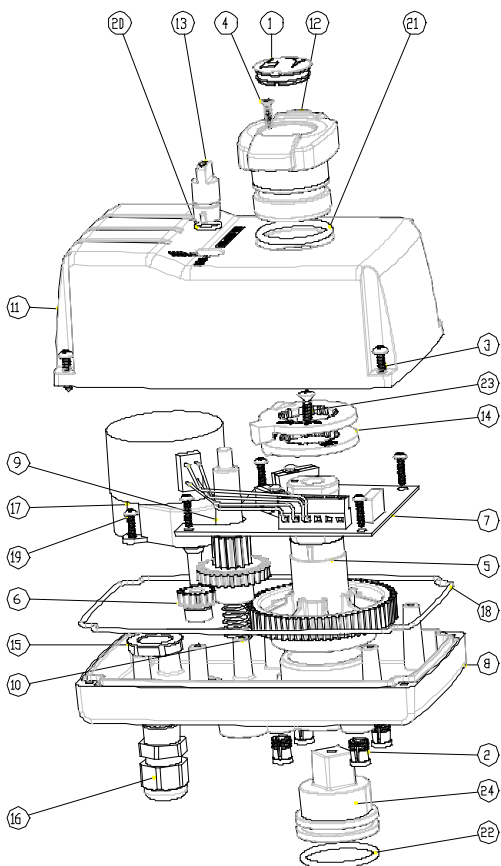

N	CODICE	BEZEICHNUNG	MATERIAL	Q
1	058107506	Kappe	PP	1
2	607305016	Buchse	Brass	4
3	711435016	Schraube	Edelstahl	4
4	711529013	Schraube	Edelstahl	6
5	05907303001	Zahnrad	POM	1
6	05907303002	Antriebsrad/Ritzel	POM	1
7	05907303003	Elektronik-Platine	-	1
8	05907303004	Basisgehäuse	ASA	1
9	05907303005	Doppelritzel	POM	1
10	05907303006	Feder	Edelstahl	1
11	05907303007	Kappe	-	1
12	05907303008	Anzeigehebel	PP	1
13	05907303009	Hebel für manuelle Schaltung	PP	1
14	05907303010	Nocke	POM	2
15	05907303011	Überwurfmutter	PA	1
16	05907303012	Stopfbuchse	PA	1
17	05907303013	Motor mit Untersetzung	-	1
18	05907303015	Dichtungsgummi	Rubber	1
19	711529013	Schraube	Edelstahl	6
20	8070091016	Dichtungs-O-Ring	EPDM	1
21	8070280030	Dichtungs-O-Ring	EPDM	1
22	8070298026	Dichtungs-O-Ring	EPDM	1
23	711539019	Schraube	Edelstahl	1
24	05907303021	Kopplung	POM	1

6. Automatisches 3-Wege Umschaltventil

D63

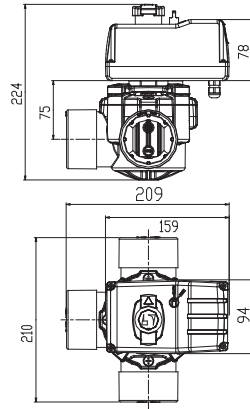
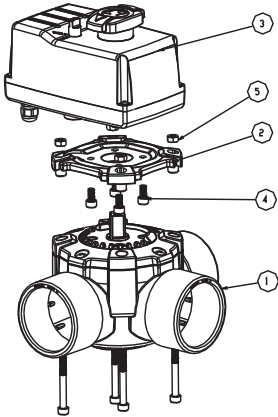

N	CODICE	BEZEICHNUNG	MATERIAL	Q
1	0590740X	Umschaltventil ohne Hebel	-	1
2	059074020	Motorhalterung	PVC-U	1
3	059073030 05907303A24	elektrischer Stellantrieb	-	1
4	710706012	Schraube	Edelstahl	4
5	71206000	Mutter	Edelstahl	4
6	710706045	Schraube	Edelstahl	4

D50

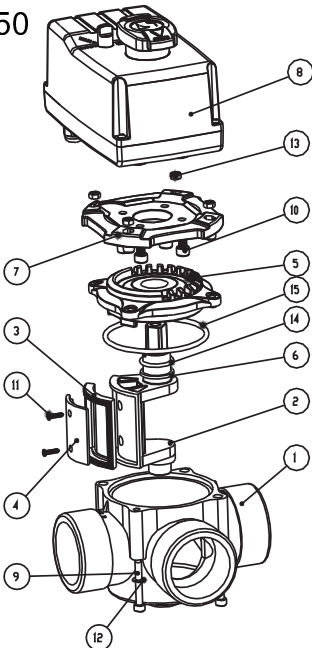

N	CODE	DENOMINACIÓN	MATERIAL	Q
1	059073000	Gehäuse	PVC-U	1
2	059073011	Drehscheibe	PPO	1
3	059072035	Klappendichtung	Silicone	1
4	059072002	Dichtungshalter	PPO	1
5	059073013	Gehäusedeckel	PPO	1
6	059072015	Flachdichtung	PTFE	
7	059073020	Motorhalterung	PVC-U	1
8	059073030 05907303A24	Elektrischer Stellantrieb	-	1
9	710705060	Schraube	Edelstahl	4
10	710706012	Schraube	Edelstahl	4
11	711429013	Schraube	Edelstahl	2
12	711905000	Zahnscheibe	Edelstahl	4
13	712105000	Mutter	Edelstahl	4
14	8070219026	O-ring	EPDM	1
15	8070758035	O-ring	EPDM	1

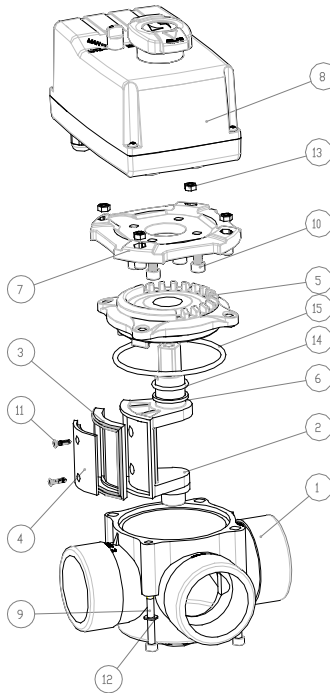

**7. Lösung möglicher Probleme**

<b>PROBLEM</b>	<b>URSACHE</b>	<b>LÖSUNG</b>
Das Ventil dreht nicht in die gewünschte Richtung	Fehlerhafter Anschluß	Das weiße und rote Kabel der Motorverbindung vertauschen und ebenso die Kabel der Verbindung des Relais untereinander tauschen
Das Ventil dreht in die gewünschte Richtung, hält aber nicht in der gewünschten Position	Die Position der Nocken ist nicht richtig	Den Hebel abnehmen, die Kappe demonstrieren und die Position der Nocken gemäß Bedienungsanleitung positionieren
	Der Anschluß des Relais ist vertauscht	Die Anschlußkabel des Relais untereinander vertauschen (braun-schwarzes).
	Einer der Detektoren funktioniert nicht	Kontakt mit dem Vertreiber aufnehmen. Kontakt mit dem Vertreiber aufnehmen
Das Ventil kann nicht per manuell bedient werden	Die mittlere Zahnradverbindung ist nicht komplett vom Motor frei	Der Wahlschalter manual/auto muß gedrückt bleiben und in die Stellung manual gedreht werden
Beim Umschalten des Ventils von manuell auf automatisch funktioniert die Automatik nicht	Der Wahlschalter manual/auto ist beim Umschalten nicht nach oben gekommen	Sicherstellen, daß beim Rückführen des Wahlschalter dieser nach oben kommt. Dies wird durch leichtes Bewegen des Haupthebels herbeigeführt, um so die Verzahnung zu erleichtern

## **WARRANTY**

All our products are warranted for a period of TWO YEARS from the delivery date. Our warranty includes repair or replacement of defective parts in our production plant or in the after-sale service location. Replacement or repair of parts under this warranty will not extend the warranty period of the original product, though such parts carry their own warranty.

For this warranty to be effective, the buyer must certify the date of acquisition and reception of the product.

For this warranty to be effective, the buyer must strictly follow the manufacturer's indications, when relevant to the product line and model purchased. No warranty is given in regard to normal wear and tear due to use of the products. Regarding fungible or consumable pieces, components and/or materials, the provisions contained in the accompanying documentation shall apply.

This warranty does not cover those cases in which the product: (i) has been incorrectly handled; (ii) has been repaired, maintained, or modified by an unauthorized person; (iii) has been repaired or maintained with other than original pieces; or (iv) has been installed or placed in operation incorrectly.

Excepting mandatory regulations to the contrary, the expenses for return and reshipment of defective materials shall be paid by the buyer. The present warranty in no way limits or prejudices consumers' rights under national mandatory regulations.



Av. Ramon Cuirans, 40 - Pol. Ind. Congost - Parcel·la 6  
08530 La Garriga (Barcelona) Spain  
Tel.: +34 93 861 27 43 - Fax: +34 93 870 98 11  
Website: [www.cepex.com](http://www.cepex.com)  
E-mail: [cepex@cepex.com](mailto:cepex@cepex.com)

Rev. 1.9 - Jan 2013